



In this issue

October 2020

Page 2



Try building these RAM drives



Page 4

At long last we're on the road again!

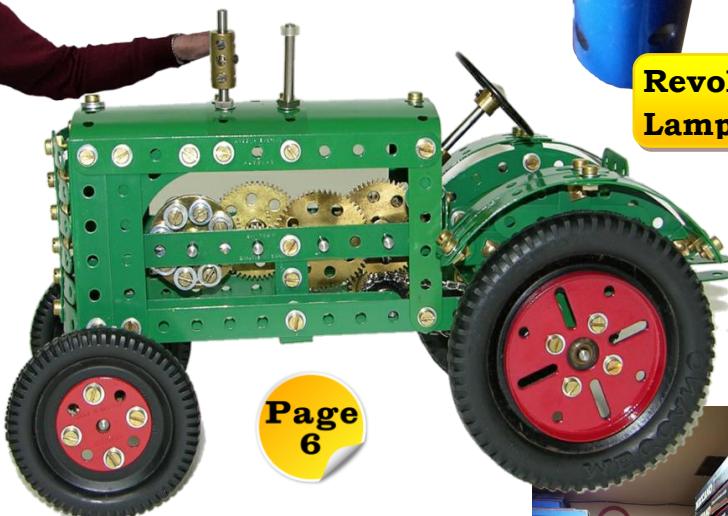
Auckland NZ club meeting Aug 9th

Build this Little Tram by Brian Neale Australia using Arduino with a little help from David Couch NZ



Page 5

Stan Knight USA does it again

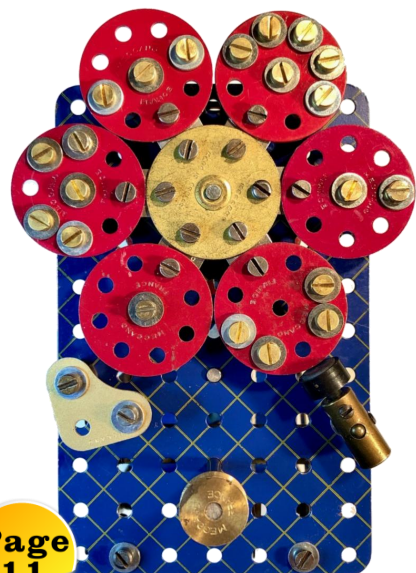
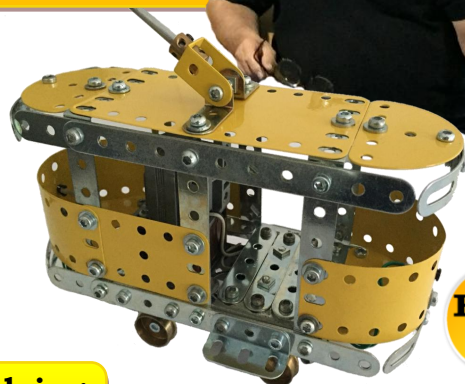


Page 6

Build this Momentum Tractor with the complete model plan inside

Revolving Lamp

Page 10



Page 11

Push-Button Die Model Plan from Peter Sullivan - Switzerland

This Month's Meccanoboy is Doug Trounce - Australia

Page 14



Page 8

Greg Rahn - Canada takes up the whole page for this issue's Show Us Your Meccano Room

GOOD IDEAS DEPARTMENT

NEW! Page 7



Plus so much more!

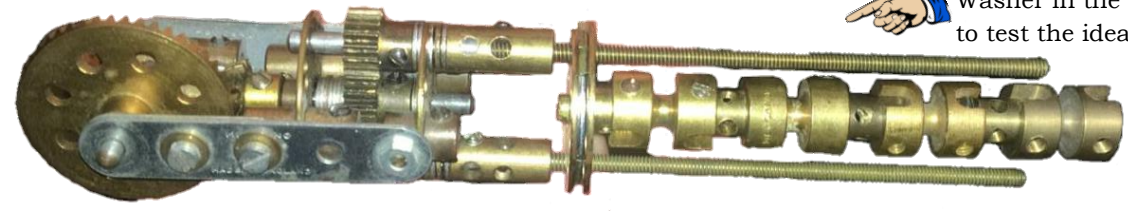
Page 1

When push comes to shove try a RAM drive

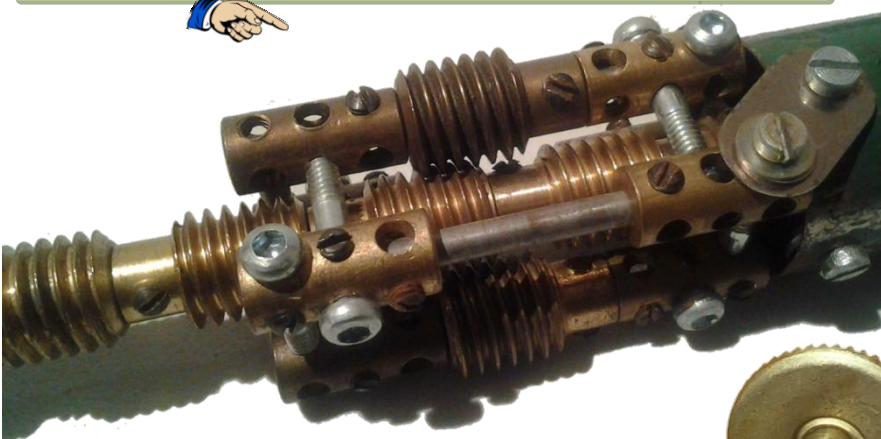


There's quite a few designs for RAM drives in the Meccano world so I thought I'd have a go at documenting some of them. Richard Payn and Tim Gant in the UK have been helping me to understand how they work and I must admit to driving them mad with endless questions!

Richard Payn used a double Screwed Rod RAM drive in his Grove Lorry Mounted Crane. There are 2 Nuts held captive between 2 Wheel Disks by means of a large Washer in the centre. This photo is an early version to test the idea that John Hornsby had of using the large Washer to prevent the square Nuts from turning. Richard also has another method of using a large Bevel Gear to hold either square or hex nuts in place as the ridge of the teeth is raised.



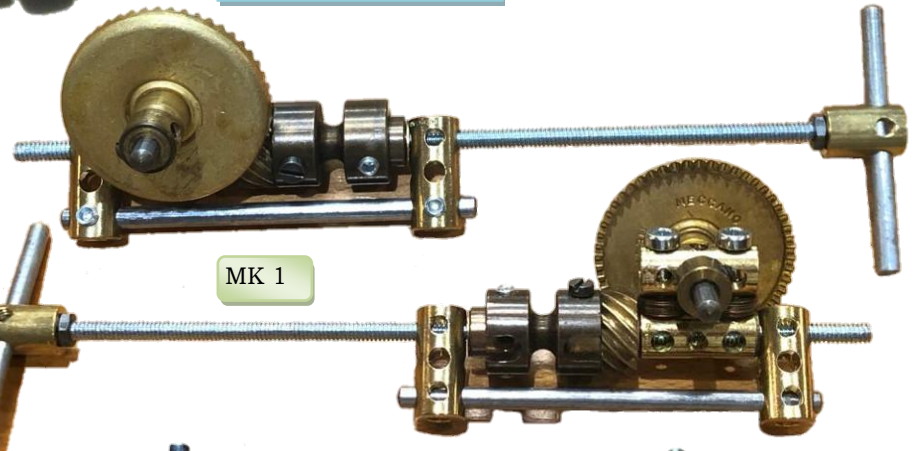
Steve Butterworth came up with another design using Worm gears.



The row of Worms on the centre Rod are rotated and as they turn they screw their way along the outside Worms that are locked in place by a series of Couplings and Pivot Bolts.

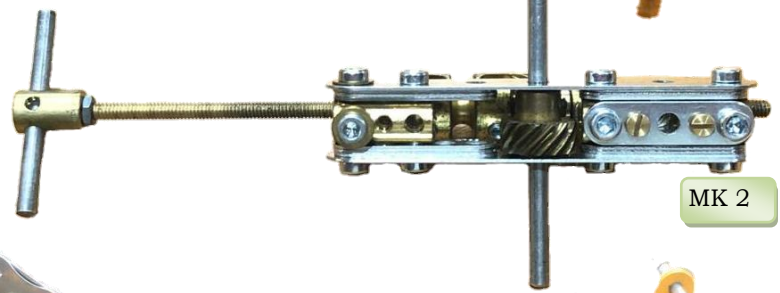


Tim Gant from the UK has been producing multiple designs. To the right is MK1. The large Bevel Gear drives the Helical Gear which in turn rotates the Threaded Boss via the Socket Coupling. The Screwed Rod is guided through the whole assembly which keeps things square. Below is MK2 which dispenses with the large Bevel and uses a pair of small Helicals.

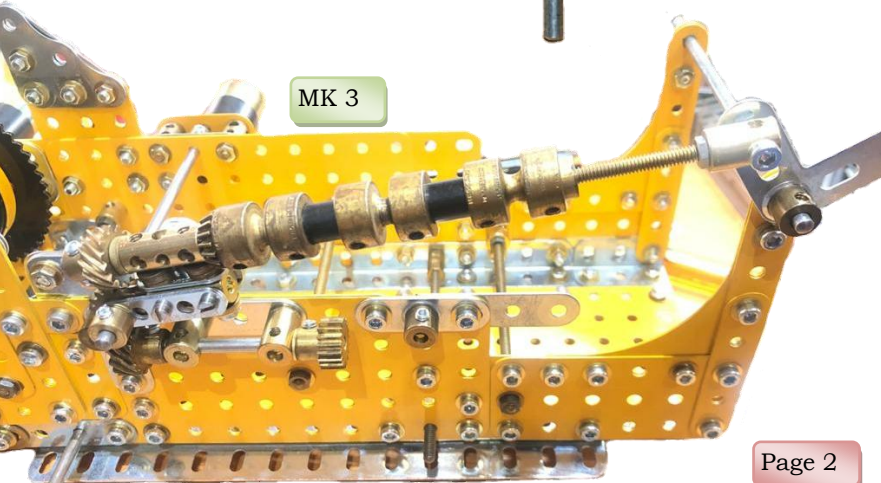


MK 1

MK 2



MK 3



MK3 uses Socket Couplings joined with black plastic Spacers. The Spacers fit tightly inside the Socket Couplings to provide an interference fit. So the drive train is: the Pinion at the bottom drives the Helical which in turn drives the centre Helical that is journalled through the centre pivot point so the RAM drive can lift up and down. The 3rd Helical in the drive chain is locked to a Rod that's journalled through the Coupling and locked to the small Bevel. All 3 Socket Couplings then turn resulting in the Threaded Boss turning and thus screwing the Screwed Rod in or out.

The ram drives that use Screwed Rods have one common theme. You turn a threaded part but it's driven from a distance, that distance being the length of travel you want. Most Screwed Rod ram drives seem to use Socket Couplings to transmit the drive but I was short of those so I started experimenting with Couplings joined together with 1/4" Narrow Strips. My 1st attempt (Fig. 3) has 4 inches of travel with a Threaded Coupling on the end. Although it could possibly be done with just 2 Couplings, I found that 4 couplings helped guide the Screwed Rod.

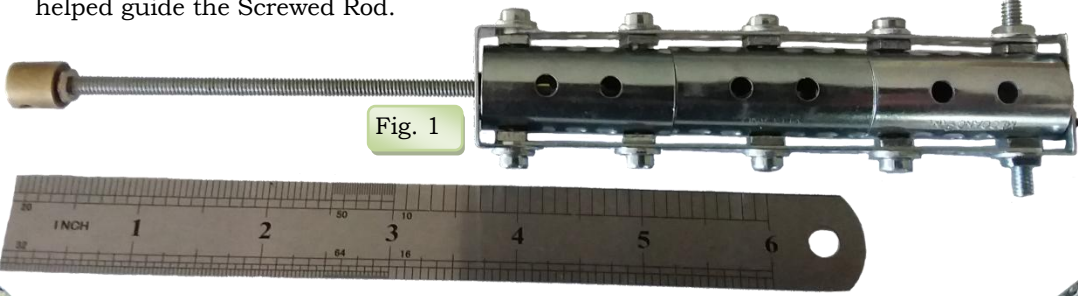


Fig. 1

I found the 6" Screwed Rod was longer than required and only gave 4" of travel anyway so I went down to a 4" Screwed Rod which fitted nicely into a 3 Coupling design shown below (Fig. 4). This gave about 3" of travel and looked quite good. The Narrow Strips are bolted to the Couplings using 69b long Grub Screws and hex Nuts. I mounted the N20 motor on a Double Bracket and pivoted it on a Double Angle Strip as you can see on the video thumbnail bottom left. Reminder, you can watch the YouTube videos by clicking on the image or you can click on the link.

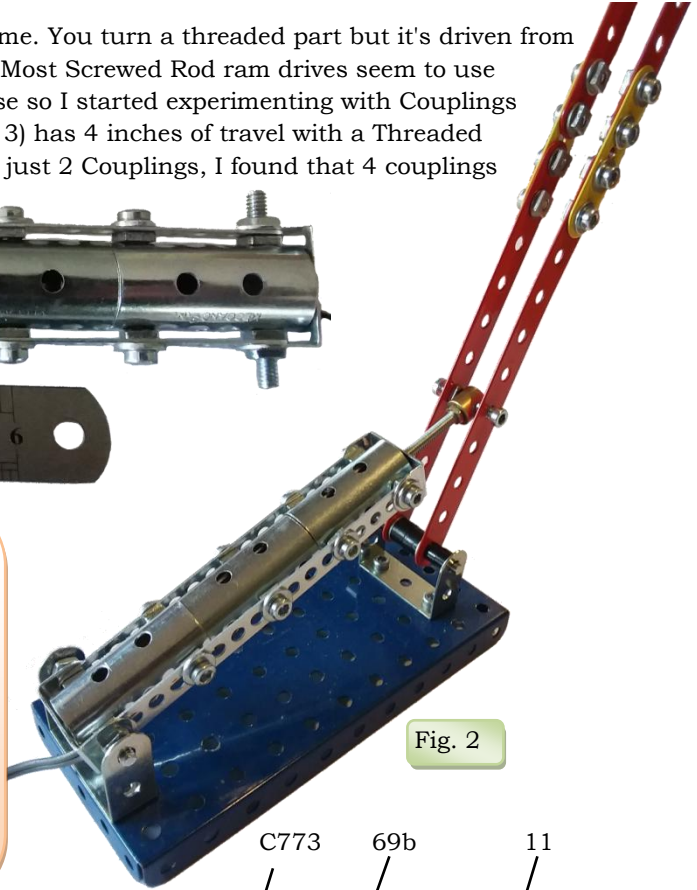


Fig. 2

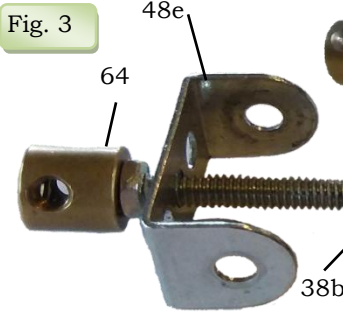


Fig. 3

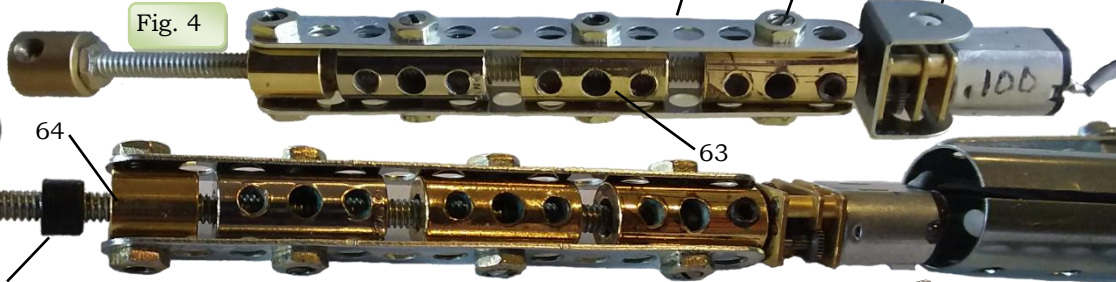


Fig. 4



Fig. 5

Mount gone. Slide in between Bolt heads

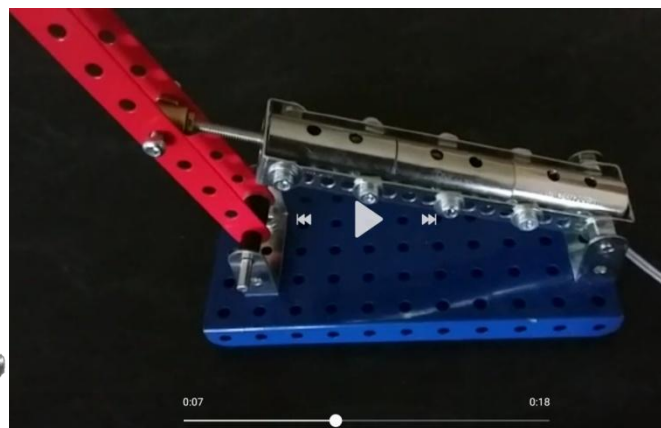
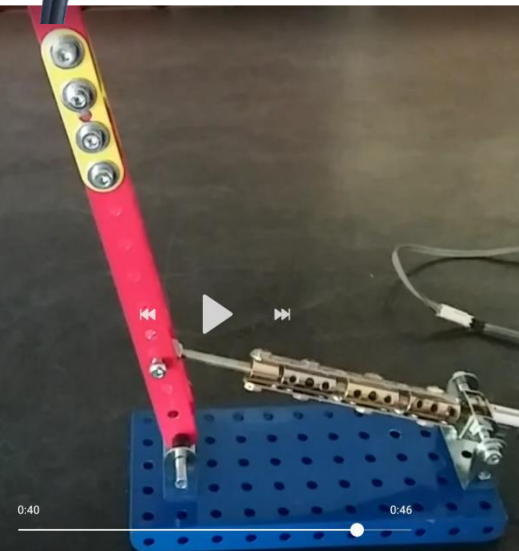
Next I started thinking about fitting the whole assembly inside Sleeve Pieces but this proved difficult as there was no room for nuts on the inside. Eventually I came up with the idea of putting the whole kit and caboodle inside 3 Sleeve Pieces by removing the Double Bracket from the motor and using 2 Bolts to perform three functions. Fig.6 The Bolt heads secure the motor. The Bolts are the pivot point. The Narrow Strips and the 48e DAS are secured to the 1st Sleeve Piece.

The N20 motor has 2 flat sides that are perfect for locking the motor in place with the Bolt heads inside the Sleeve Pieces. It's important to ensure the motor terminals are insulated from the DAS. I used Araldite. Silicon or insulation tape will also work. There's a small black Spacer that pushes the N20 hard against the DAS to keeps things nice and tight. Fig.5. The Narrow Strips are bolted to the DAS at the other end and all 3 Sleeve Pieces are kept in place by the Bolts that go into the holes but do not protrude inside. If you watch the video bottom right, you will notice that the Sleeve Pieces jiggle around a bit. I think I prefer it without the Sleeve Pieces but watch both videos and you can be the judge.

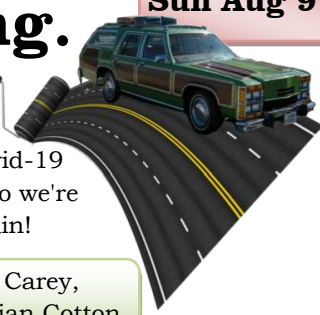


Fig. 6

X-Ray view of N20 motor inside the Sleeve Pieces



At last! Auckland NZ Meccano meeting.



New Zealand has done very well getting Covid-19 under control so we're on the road again!

Mike Stuart, Neil Carey, Rick Vine and Brian Cotton.



Les Megget left and David Wall discuss a model of the Wellington floating crane, the Hikitia.



William Irwin and Neil Carey discuss a new strip roller built by William.



Holly Wrightson, Frans Ennen and Keegan Wrightson examine models of the floating crane & a no 8 set tank.



Neil Carey NZR J 1212 locomotive used from 1958 to 1969. Neil is an ex engine driver from NZ Railways.

Frans Ennen, Keegan Wrightson, Brian Cotton and Rick Vine at the model table.



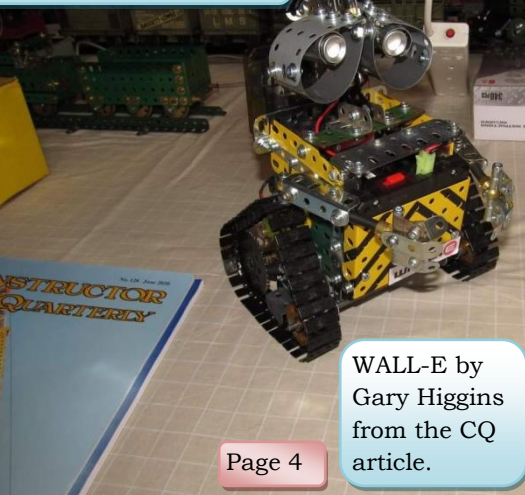
Keegan Wrightson steam excavator S.31 in the supermodels book. The vertical engine has been replaced with a horizontal version.



Mike Stuart Giant Blocksetting Crane

EVE! ❤️
EEEVA!

William Irwin, Graeme Mills and Neil Carey discuss bending Meccano with a roller.



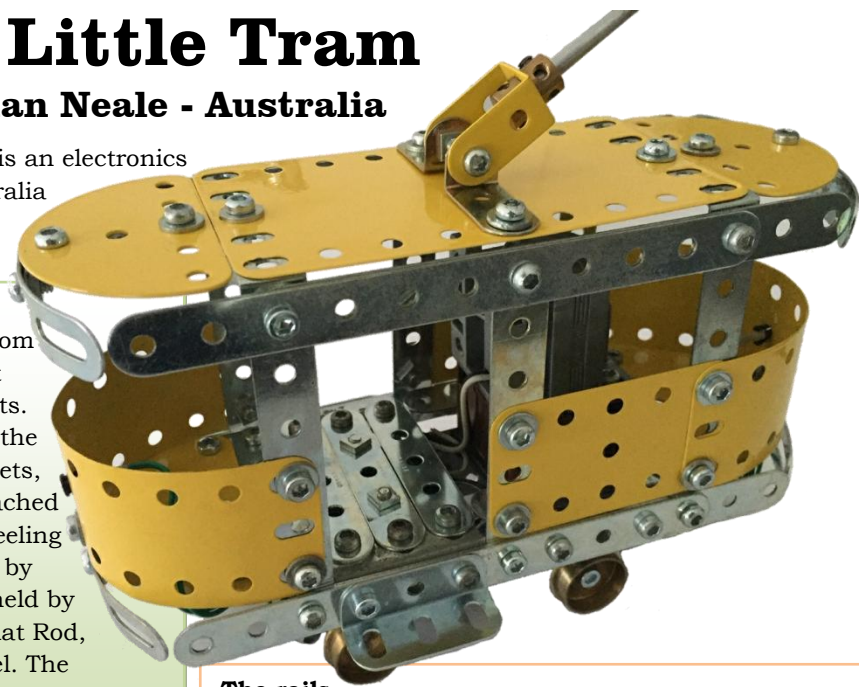
WALL-E by Gary Higgins from the CQ article.



The Little Tram

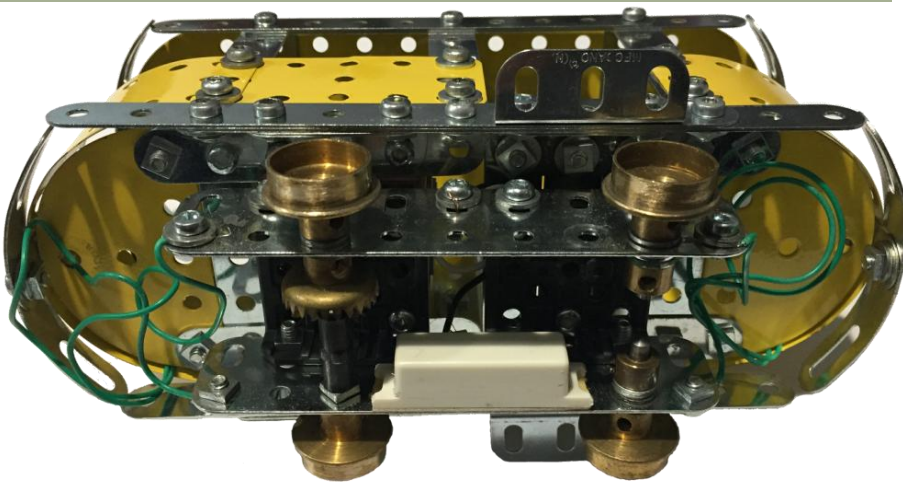
by Brian Neale - Australia

Note: Jaycar is an electronics store in Australia and NZ.



A project by David Couch to incorporate "Meccano and Arduino". David published a set of documents on the NZ Meccano web site describing how to go about controlling a Meccano model using Arduino. I would personally like to thank David for his help while building my project.

The tram uses a two-rail power supply, which means that the rails and wheels on opposite sides must be insulated from each other. My chassis of the tram consists of two 4½" Flat Girders connected by two part D485 Plastic Double Brackets. The Plastic Double Brackets are placed leaving one hole at the end of the Flat Girders. On one of the Plastic Double Brackets, I mounted a part 760 Gearbox fitted with a 19t Pinion. Attached to the Gearbox is a "silver stylised" Motor. The two free-wheeling Flanged Wheels are mounted on 1" Axle Rods held in place by Collars. The drive wheels are also Flanged Wheels. One is held by a Screw into a part C135 Connector which has a 1½" Tri Flat Rod, fitted with a Contrate Wheel as well as the other drive wheel. The magnet is attached by self-adhesive tape to one of the 4½" Flat Girders.



The rails

The rails are Angle Girders placed 2½" apart. They are supported by six part D353 plastic Double Brackets. There's no limit to the number of Girders you could join together. The switch part of the magnetic switch is attached to the rails a short distance from each end. The magnet on the chassis must just clear the switches.

Preliminary testing

At this point the chassis can be tested by connecting a suitable power supply to the two rails and placing the chassis on the rails. If it runs erratically, clean the top edges of the rails and the rims of the Wheels with a piece of fine emery paper or sandpaper.

The tram body

The design of the tram is based on model no. 3.5 in the 1958 no. 3 Outfit manual.

Apart from being a plagiarist, sorry David, I've been a lifelong Meccano fan. I am a member of the Melbourne and the South East Queensland Meccano Clubs. I would probably be classified as a "Lurker" on the Spanner group. I am retired from working in the Automotive Electrical, Gaming Machines and Photo Copier business. I enjoy working with Meccano but I've been looking to put more life into my models.

Follow Brian on Instagram. His moniker is meccanofan

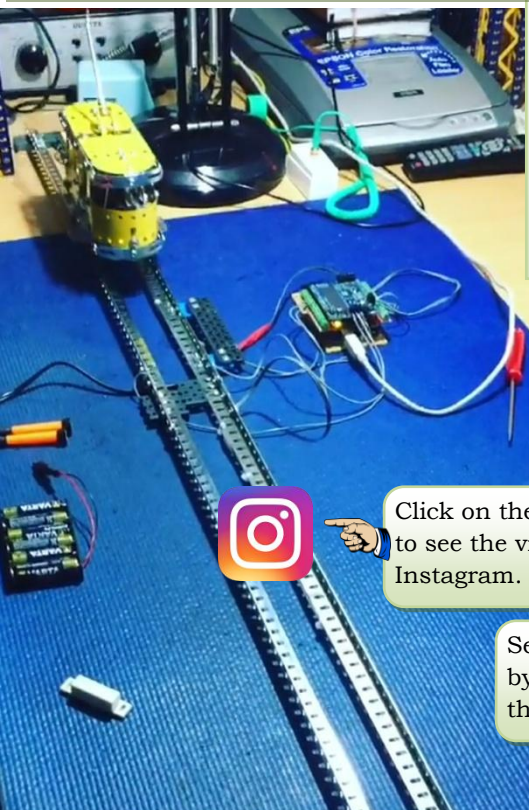
Click the Instagram icon 



As you will see I am also not too good at following written instructions. If, like me, you don't already have Arduino parts, I suggest

you look closely on the web. There are a few good Australian based electronics companies that can supply all you need. I purchased a Duinotech Mega Microcontroller and a Duinotech L293D Motor Control Shield from Jaycar. That was my first mistake. Jaycar don't advertise what Version their Motor Shields are and, naturally to newcomers, I thought they were all the same. My second mistake was I didn't follow the instructions. David's documentation clearly talks about purchasing the Version 2 Motor Shield. I spent hours trying to get the project to work. I even went and bought a second Motor Shield from Jaycar thinking I had damaged the first.

The Jaycar shields are only Ver. 1. Once I had the Ver. 2 board things fell into place. Another mistake was forgetting to remove the Voltage-in jumper of the Motor Shield. This jumper allows you to connect a power source for the motor rather than use the Arduino low current power. I am very happy with my Little Tram but I have a lot more learning to do. I suggest you have a look at David's documentation on the NZ Meccano web site, but make sure you don't make the same mistakes I've made.



Click on the photo to see the video on Instagram.

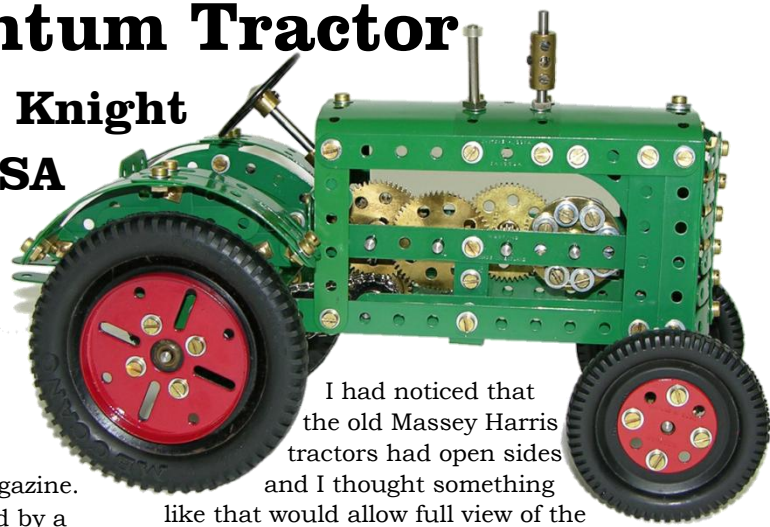
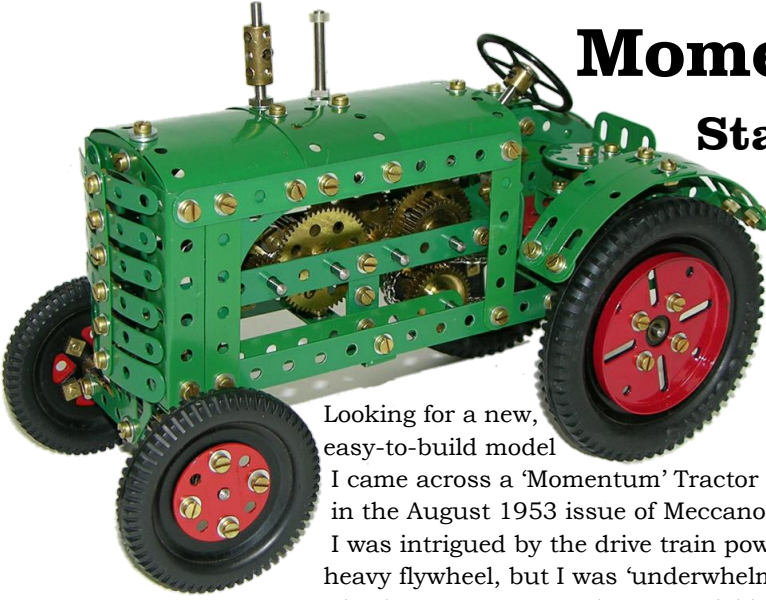
See the instructions by David Couch in the nzm gallery here.



Momentum Tractor

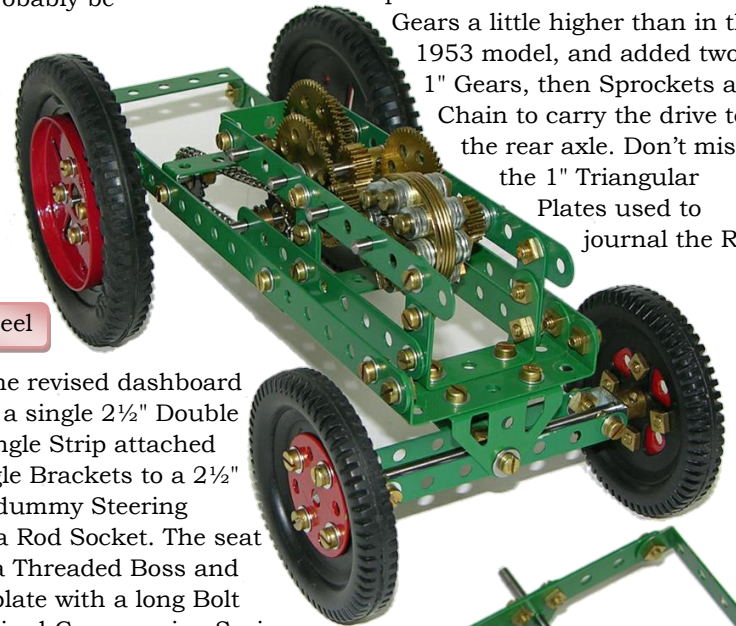
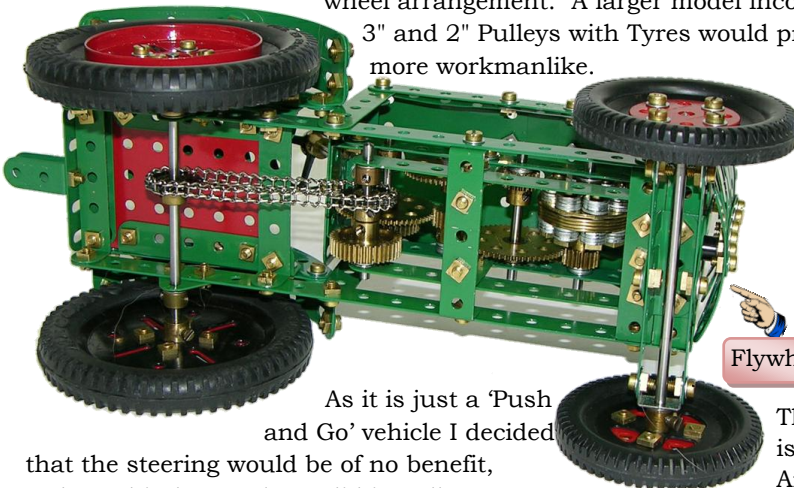
Stan Knight

USA



Looking for a new, easy-to-build model I came across a 'Momentum' Tractor in the August 1953 issue of Meccano Magazine. I was intrigued by the drive train powered by a heavy flywheel, but I was 'underwhelmed' by the wheel arrangement. A larger model incorporating 3" and 2" Pulleys with Tyres would probably be more workmanlike.

I had noticed that the old Massey Harris tractors had open sides and I thought something like that would allow full view of the operating mechanism as the tractor rolls along. So this is my adaptation of that momentum drive. I raised the three pairs of 19T Pinions and 57T



Gears a little higher than in the 1953 model, and added two 1" Gears, then Sprockets and Chain to carry the drive to the rear axle. Don't miss the 1" Triangular Plates used to journal the Rod.

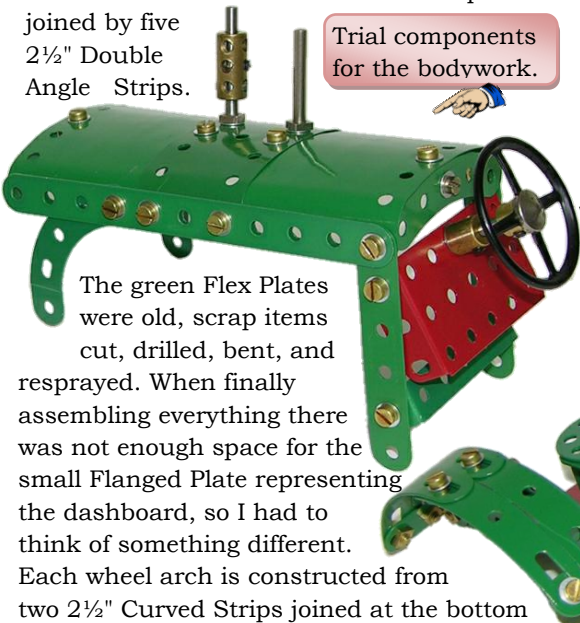
Flywheel

As it is just a 'Push and Go' vehicle I decided

that the steering would be of no benefit, rather a hindrance, but I did install a rocking front axle. The Narrow Strips make for a neater axle beam. The main chassis frame is formed with 9 1/2" Strips joined by five 2 1/2" Double Angle Strips.

Trial components for the bodywork.

The revised dashboard is a single 2 1/2" Double Angle Strip attached with Oblique Angle Brackets to a 2 1/2" Flat Girder. The dummy Steering Wheel is held in a Rod Socket. The seat is supported on a Threaded Boss and held to the Baseplate with a long Bolt through an oversized Compression Spring. The Wheel Discs for the front hubs and seat were resprayed just for this model. My large (non-standard) Wheel Flanges on the rear wheels could be replaced with Face Plates or normal Wheel Flanges.

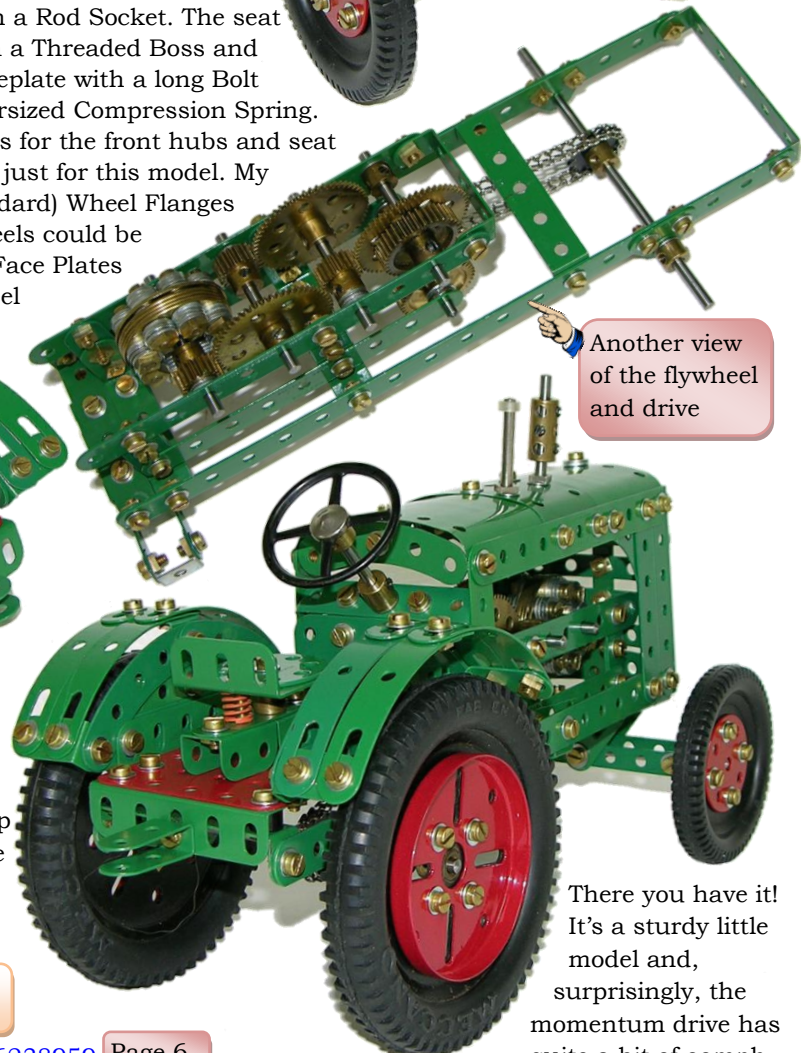


The green Flex Plates were old, scrap items cut, drilled, bent, and resprayed. When finally assembling everything there

Another view of the flywheel and drive

was not enough space for the small Flanged Plate representing the dashboard, so I had to think of something different.

Each wheel arch is constructed from two 2 1/2" Curved Strips joined at the bottom by a (non-standard) 4" Strip - two short Strips overlapped could be substituted. The space above that Strip is filled in with a 2 1/2" Strip, held in place by a 1" x 1" Angle Bracket which also holds the Formed Slotted Strip mudguards. The Baseplate is a (non-standard) 3" x 2 1/2" Flat Plate - a 2 1/2" x 2 1/2" Plate plus a 2 1/2" Strip could be used instead, or two 3" x 1 1/2" Flat Plates overlapped one hole. The radiator (top left photo) is made from Narrow Strips curved in a strip roller and forms a style reminiscent of the old Massey Harris tractors.



There you have it! It's a sturdy little model and, surprisingly, the momentum drive has quite a bit of oomph.

The Aug 1953 Meccano Magazine can be downloaded for free from Tim Edwards' website here.

<https://meccanoindex.co.uk/MMpage.php?MID=26017&id=1596238959>

FROM OUR GOOD IDEAS DEPARTMENT

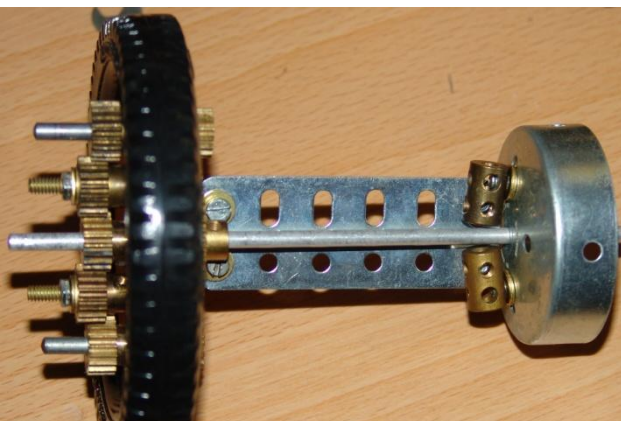


Ronald Frith from the UK has come up with a very neat way to add tread to your tractor wheels. He uses the plastic track from the Army Multikit outfits.

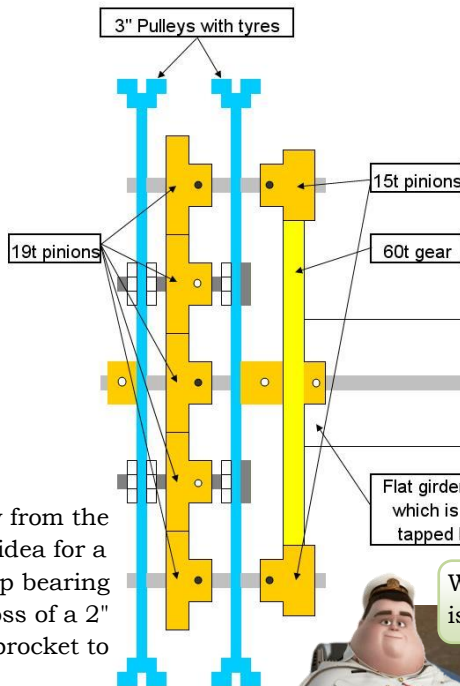
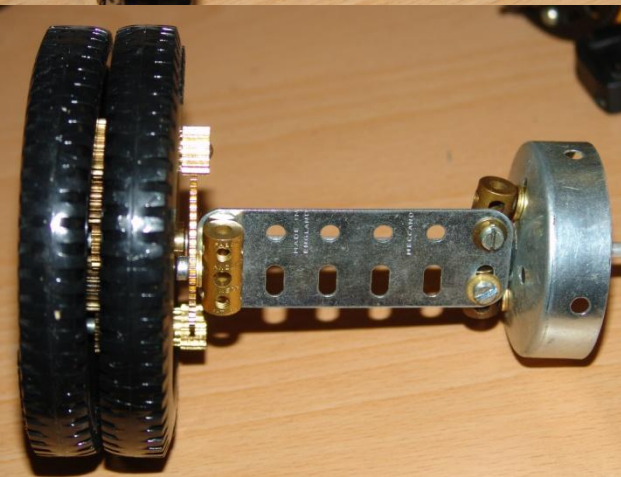
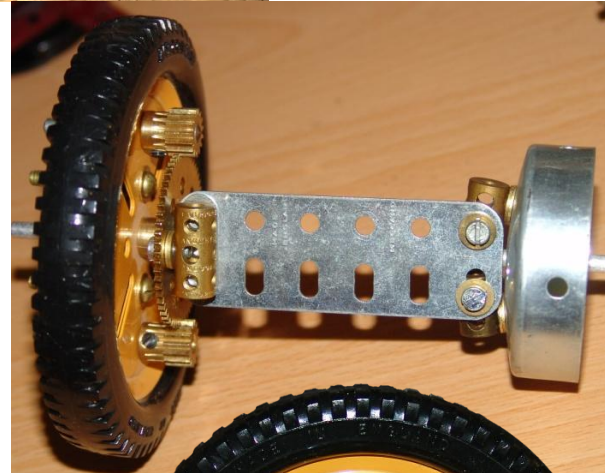


Tips and Tricks from our readers

5:1 Hub Reduction from Richard Payn - UK



The construction should be clear from the images. The Flat Girder can be swapped for one that suits the width of axle required. The differential would be the standard Meccano unit housed between a pair of Boiler Ends spaced by 2" Strips. As the half shaft rotates, the drive is taken via the 19t Pinions to the 15t Pinions which revolve around the 60t Gear.



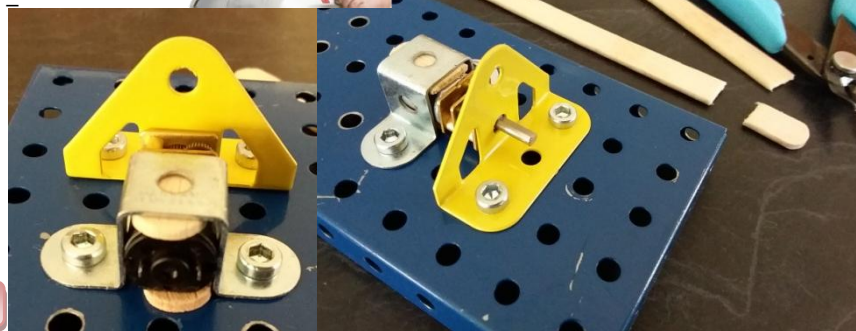
N20 motors fit nicely inside a part 45 Double Bent Strip. You can get the shaft to line up with standard hole spacing by using ice cream sticks.

Warning. Ice cream is fattening!



John Hornsby from the UK has an idea for a handy cup bearing for the boss of a 2" or 3" Sprocket to sit in.

Richard Payn UK, uses this idea to pivot the main jib on his Sobemai Crane. It's easy to slot in and out.

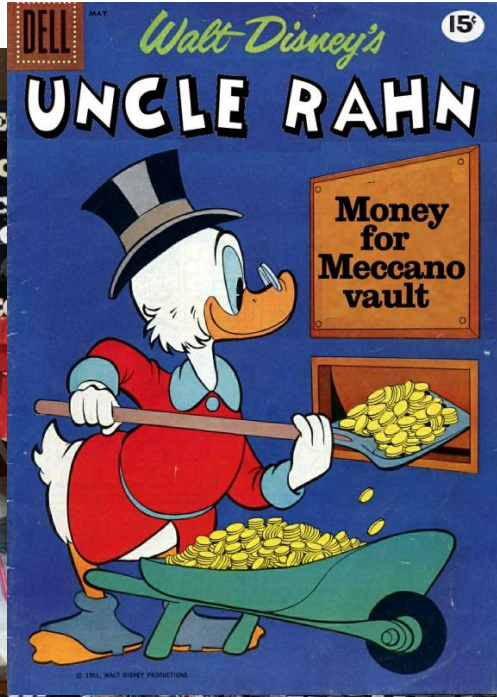




Show us your Meccano room

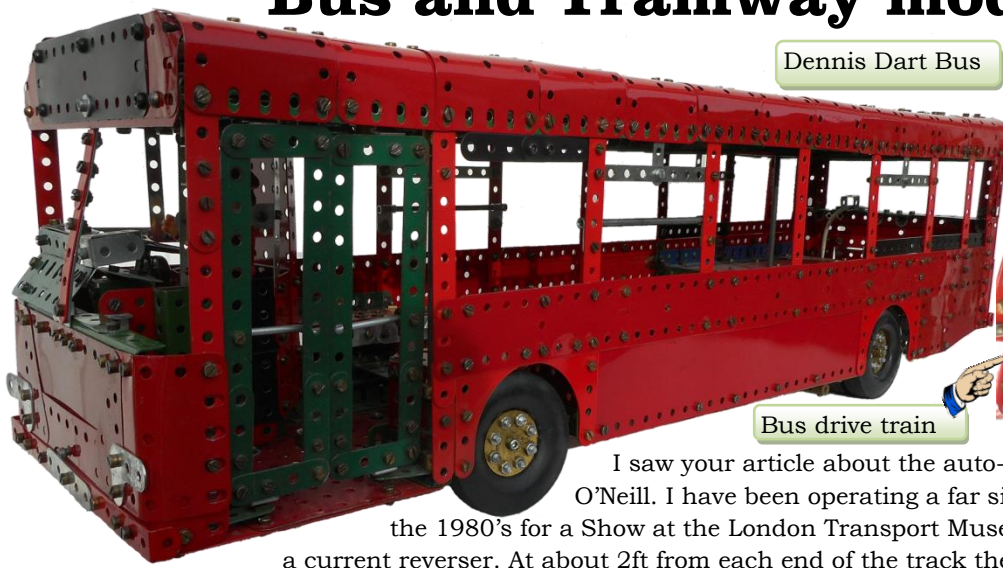
Is this the world's biggest Meccano Room?
submitted 24 photos! Here's just a few.

Greg Rahn - Canada

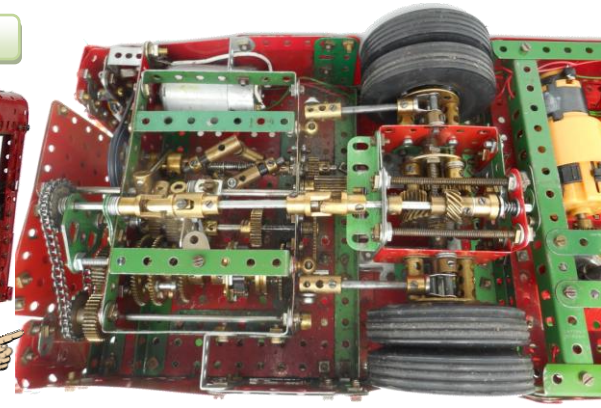


Bus and Tramway models - Michael Edwards - UK

Dennis Dart Bus



Bus drive train



I saw your article about the auto-reversing system for railed vehicles by Graeme O'Neill. I have been operating a far simpler system on my 3.5 inch tramway, built in the 1980's for a Show at the London Transport Museum. It has no complicated moving parts except a current reverser. At about 2ft from each end of the track there is a diode on one rail joining up a gap where

the track is cut. A diode allows current to pass only one way. These are wired so that, when the tram approaches, the end of the track is dead and the model coasts to a stop. When the current reverses the end of the track becomes "live" and the tram proceeds in the opposite direction where the same thing happens. The auto-timer consists of a Meccano Crouzet motor driving a commutator using the half-on/half-off part to turn a relay on and off at regular intervals depending on the revolution speed. The power is wired into the relay so that it is reversed when it switches. The result is a regular movement of the model, with automatic stopping and waiting at each end of a 22ft track. To make the model more realistic I devised a speed control on the trams where a Meccano rubber band driven off an axle causes an Elektrikit wiper arm to travel across a resistance mat (produced by H&M as a spare) thus making the motor start slowly and gather speed. Once the arm has travelled to its limit, the rubber band simply slips on the axle. I have incorporated a boiler-end Meccano bell to "ding" as it travels. The traction power goes through the rails, one being a common earth with the overhead, which operates the lights. By this means the lights stay on when the motor is stopped. The overhead is a separate supply at 12V. A final touch is wiring a relay in each tram to read the direction of the light circuit so that two trams running simultaneously can be individually controlled. The bus is modelled on the Dennis Dart, often seen in the UK until recently.

The gearbox is operated by a centrifugal governor made up of couplings and collars and 3 central Meccano springs in a row.

As it speeds up the weights fly out pulling the input shaft through the 3 sets of gears. As neutrals between the speeds would cause the model to stop and gears to crunch, I devised a neutral free transmission based on ratchets, which consist of 4 spring on a bush wheel clicking round a 19t pinion. Both neighbouring gears are engaged momentarily, but the faster one takes up the drive and the lower gear slips on its ratchet. Under load it will change back up again as the governor slows.

Auto Timer with a Crouzet motor and half-on/half-off commutator.



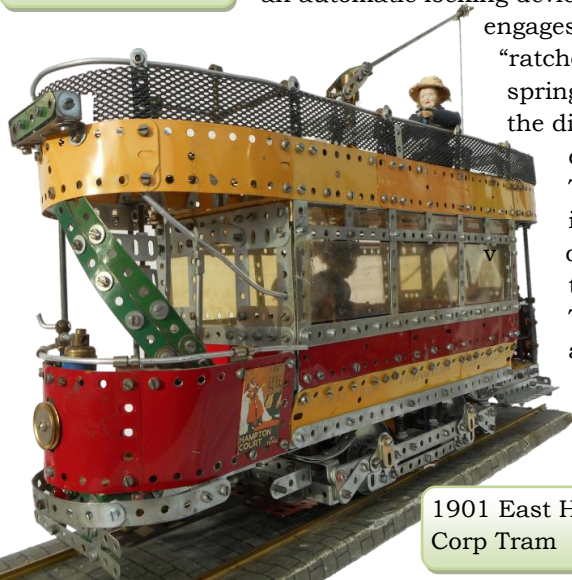
1935 HR2 London Transport Tram

Between second and top gears there is an additional device which provides synchromesh allowing the gears to engage easily without pressure. There is also an automatic locking device to prevent gears changing whilst in reverse. This engages a non-ratchet gear, as otherwise the gears would just

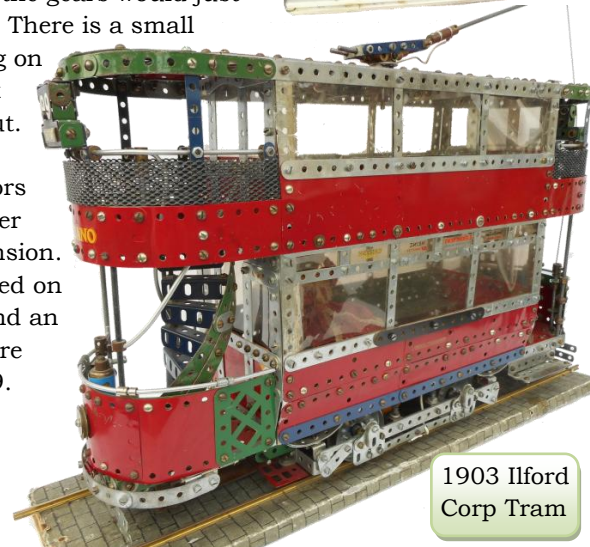
"ratchet" and the model would not move. There is a small spring on the input drive thrust bearing on the differential which absorbs the shock of the gear change, smoothing it out.

The model is remotely controlled, including steering and opening doors operated by Power Drive Units under the flooring, and coil spring suspension. The model travels at a realistic speed on a long multi-core cable. The bus and an earlier version of the gearbox were featured in CQ83 in March 2009.

The governor was described in MM December 1966.



1901 East Ham Corp Tram



1903 Ilford Corp Tram

Revolving Warning Lamp

The Thunderbird is a retro model that I remember from childhood so I thought a retro warning light was in order. Remember the old fashioned warning lights that had a light globe that turned around? These days they're usually electronically controlled flashing LEDs.

I still used an LED but to make it rotate I need an N20 geared motor and a commutator. I remembered a broken USB fan that was lying about and because it had a flashing light to make a pattern when it was spinning, I reasoned that it must have a commutator inside. It was broken anyway so I salvaged the disc shaped commutator and was happy to see the copper plate circle had a contact on the other side so it was a simple matter to solder a wire to it. You can also use some copper clad board that is available in electronic stores or eBay.

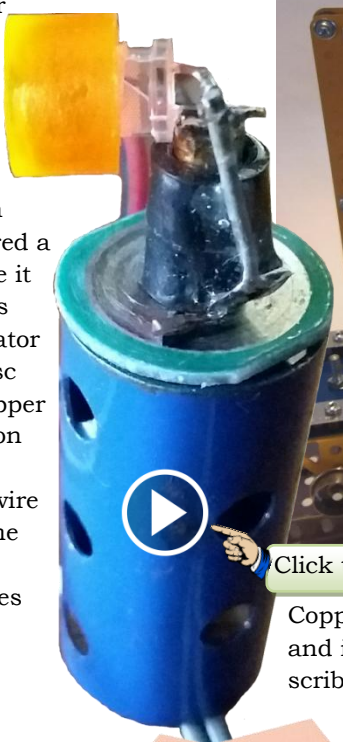


Wiper soldered to lead.



These USB fans with lights only cost a few bucks.

Current limiting resistor for LED. For 12V use 470Ω



Click to see it work!

Copper clad board is used to make Printed Circuit Boards and is inexpensive. Use a Sleeve Piece as a template to scribe a circle then cut it out using a hacksaw and a file.

You will need to drill a 4mm hole for the motor shaft and a 1mm hole for the resistor lead to pass through. Make sure the solder joint isn't where the wiper will pass.



Copper clad boards.

The wiper can be salvaged from any old broken motor. The modern Meccano motors are OK or if you have an old cassette player or VCR that will do. It's just a matter of breaking open the motor and removing the wipers.

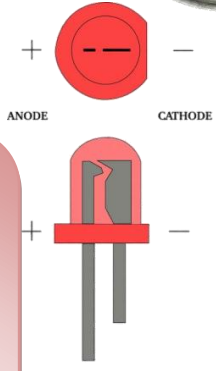


Wipers.

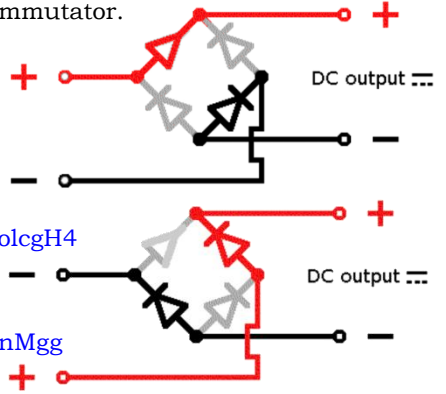
Once you have the wipers, place the commutator over the motor and put 2 plastic Spacers on making sure the brass sleeve is protruding just enough to allow you to solder the cathode of the LED onto the motor shaft. Note: You can't solder to the original steel 3mm shaft as the solder won't take. Now use a bit of thick 'solderable' wire (I used the lead of a diode) and solder the wiper to the end of it. Solder the other end to the anode of the LED at just the right length to be sure the wiper is touching the copper on the commutator. Then secure the lead to the plastic Spacer with Araldite. The LED, Spacers and wiper all rotate around the stationary motor and commutator.

The negative is soldered to the motor lug as well as the motor body. The positive is soldered to the other motor lug as well as the 470Ω resistor. The other end of the resistor is soldered to the copper plate on the commutator. The LED should now be tested to make sure it works.

Troubleshooting. Make sure you have the LED the correct way around. The cathode is the lead with the flat side on the LED. Use a multimeter to make sure the wiper is contacting. You should see zero ohms between the body of the motor and the cathode of the LED and 470Ω between the the positive lug of the motor and the anode of the LED.



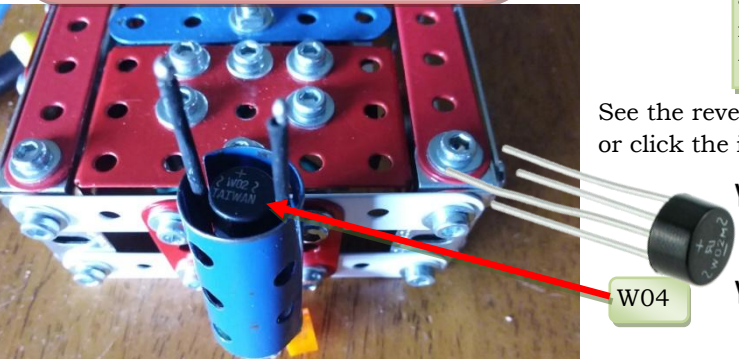
To make this lamp work with either polarity there's a trick you can use with a bridge rectifier. These are usually for converting AC to DC but if you put DC in you get DC out. See the diagram to the right. I used a W04 which is rated 400V 1.4A and cost AU\$1.95. Solder the negative lead to the motor lug that's connected to the motor body and the positive lead to the motor lug that's connected to the resistor.



See the reverse polarity operation here or click the image to the left.

YouTube <https://youtu.be/BhqTHolcgH4>

See another video here YouTube <https://youtu.be/IwTzlrnMgg>



W04

Build your own Push-Button Die!

Peter Sullivan

- Switzerland

An amusing model that can be used to entertain young and old or as a substitute in a traditional game of dice. One obsolete part, 129 Rack Segment, is required to build the impulse spin drive and it's a classic example of how this unusual part can be used. Ashok (India) has this reproduction part available for sale, but I used my one and only nickel plated 129 French original part in the prototype!

Construction of the Frame.

See Fig 2 and 3. Commence by assembling the open box frame. A Flanged Plate, part 52, forms the base with a 3½" x 2½" Flanged Plate, part 53, secured at one end with two Bolts, flanges inward and two 3½" Strips at the other end for the vertical sides. The top edges of the box are strengthened by the two 5½" Angle Girders, slotted holes facing down, with the frame top face completed with a 5½" x 3½" Perforated Plate bolted to the girder ends. A 3" Strip (Fig.2) adds triangular rigidity to the structure and an additional 3½" vertical Strip is bolted on the other side, 4 holes from the end of the Flanged Plate. This Strip acts as the stop for the Rack Segment in its rest position. A 2½" x 1" Double Angle Strip is attached next to the sector stop 3½" Strip. It is bolted lugs up to the inside faces of the top Angle Girders and will form the plunger guide. A Flat Trunnion (or similar) on the other side (see Fig.2) locks the Double Angle Strip in a vertical position and will require a thin spacing Washer between the Trunnion and the lug of the Double Angle Strip to pad out the spacing to that of the Angle Girder thickness – about 1/30" or 0.85mm, so the "sandwich" is not distorted.

Construction of the Impulse drive.

A 3½" Rod is journaled between the top and bottom Plates as can be seen in Figs 3 and 4. It is fixed in place by a Collar and Washer above and a 1" Pulley (or 2nd Collar) and a Washer below the Base Plate.

The same Rod carries a Bell Crank. The Rack Segment is double bolted to the underside of its left arm.



Fig 1

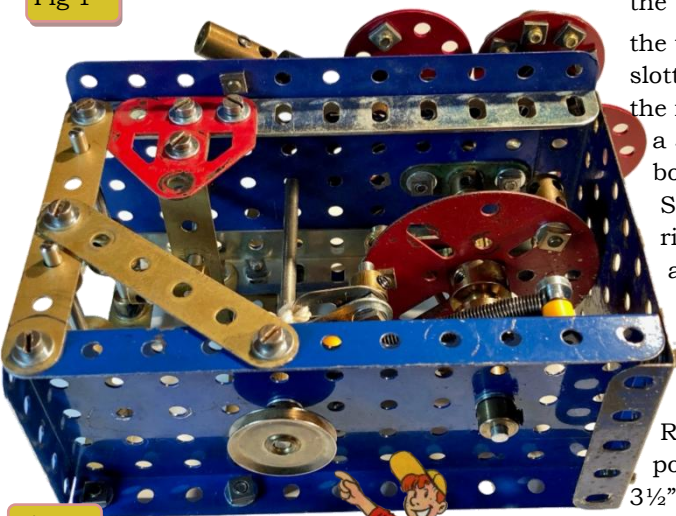


Fig 2

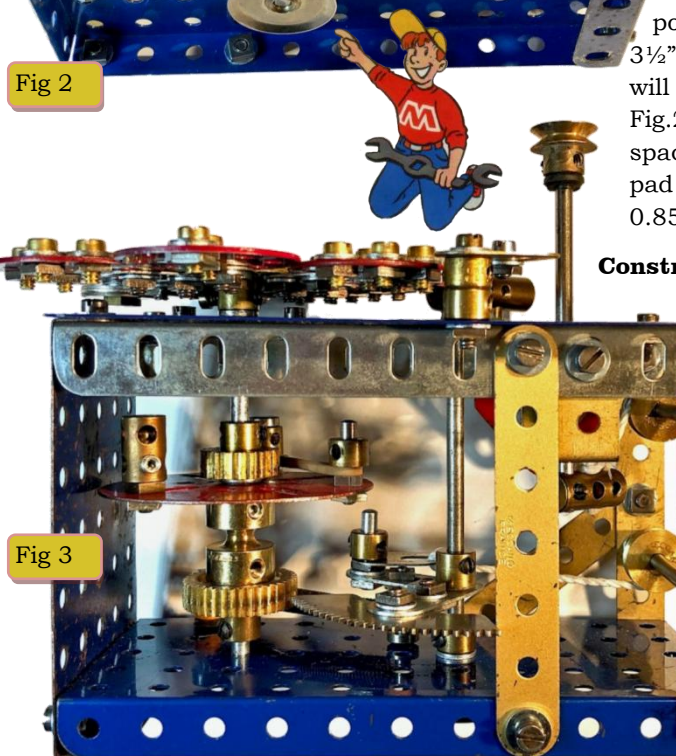


Fig 3

Part No.	Description	Qty
3	Perforated Strip, 3½"	3
4	Perforated Strip, 3"	1
9	Angle Girders, 5½"	2
10	Fish Plates	7
15b	Axle Rods, 4"	1
16	Axle Rods, 3½"	2
16b	Axle Rods, 3"	2
22	Pulley Wheels, 1" with set screws	1
23	Pulley Wheels, ½" without..	2
23a	Pulley Wheels, ½" with..	1
24a	Wheel Disc, 8 holes, without boss	6
24b	Bush Wheels, 6 holes	1
31	Gear Wheels, 1", 38 teeth	1
37a	Nuts	68
37b	Bolts, 7/32"	59
38	Washers	31
38a	Plastic Spacer	2
38d	Washers, 3/4" diam.	3
43	Tension Spring, 2" long	1
46	Double Angle Strips, 2½"x1"	1
52	Perforated Flanged Plates, 5½"x2½"	1
52a	Perforated Flange Plates, 5½"x3½"	1
53	Perforated Flanged Plates, 3½"x2½"	1
59	Collars with Set Screws	11
62b	Double Arm Cranks	1
63	Couplings	1
63c	Couplings, threaded	1
63d	Short Couplings	1
109	Face Plates, 2½" diam.	1
111	Bolts, 3/4"	1
111c	Bolts, 3/8"	1
115	Threaded Pins	4
126a	Flat Trunnions	1
128	Bell Crank with Boss	1
129	Rack Segments, 3" diam.	1
133a	Corner Brackets, 1" diam.	1
147a	Pawls	1
147b	Pivot Bolt with 2 Nuts	3
148	Ratchet Wheels	1
171	Socket Couplings	1
537a	Round Magnet in ½" holder	1
	Small elastic band	1
	Small rubber ring 4mm ID	1
	4mm paint protection thin washers	As reqd

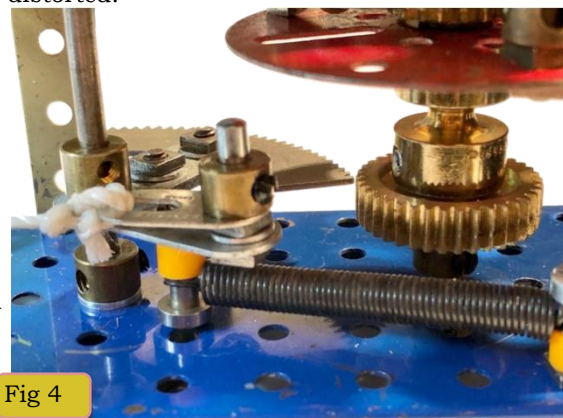


Fig 4

Construction of the impulse drive. Cont.

A Pivot Bolt is fitted to the right arm, head downwards in the inner slotted hole, and positioned so the shank of the thread is up against the outer end of the slot. The same Pivot Bolt is carrying a Plastic Spacer and 2" Tension Spring (see Fig. 4). The other fixed end of the Spring is fixed to the Base Plate by a similar arrangement using an upright Pivot Bolt and Spacer. With the fixed pivot end in the second outer hole from the end of the Base Plate, the Spring should be just in tension with the Segment arm in its rest position against the 3 1/2" Strip. The Bell Crank height should be adjusted so the inverted Pivot Bolt head clears the Base Plate by about 1/20" (a standard Meccano Washer thickness). As shown in Fig.4, the Bell Crank's right arm also carries a Threaded Pin in its outer round hole on which a cord attachment Fish Plate is held in place by a Collar. It will be necessary to add a Washer or two so the Fishplate clears the Nut on the end of the Spring Pivot Bolt when the drive plunger is released. The plunger assembly is made from a 3 1/2" Rod sliding in the middle hole of the 2 1/2" x 1" Double Angle Strip and corresponding top Plate hole. A 1/2" Pulley forms the push-button, and a strong cord tied to a Coupling at the other end of the Rod transmits the impulse to the Fish Plate on the Bell Crank. As Figure 5 shows, the cord is guided over two 1/2" free running Pulleys each located on separate 3" Rods, both journalled in the frame end 3 1/2" vertical Strips and held in place by Collars. The cord, which must be of a non-elastic type, should be adjusted so that the plunger is as high as possible when the Rack Segment is at rest. A small Rubber Pulley under the plunger push knob Pulley will protect the paint on the top Plate. I used one sliced in half. Once things are adjusted, it's also a good idea to put a drop of superglue on the cord knots to prevent them working loose when the plunger is being hammered by enthusiastic gamers! The plunger should move and return freely under the action of the Tension Spring. Check that nothing is catching or snagging at this point, and a small drop of oil on the plunger shaft will help for a smooth action.

Construction of the Die Score Disk and free-wheeling drive shaft.

The Rack Segment arm engages with a 1" Gear joined by a Socket Coupling, part 171, to a free-wheeling assembly that imparts a spin to the die disk. Inertia will cause the disk to continue spinning for a short while until it comes to rest. A small Meccano Magnet on the top plate attempts to detent the position of the stationary disk so the score disk falls in line with the marker. It works most times, but a stronger Magnet or possibly 2-3 of p/no 537a might work more reliably – that is up to you to experiment and improve!

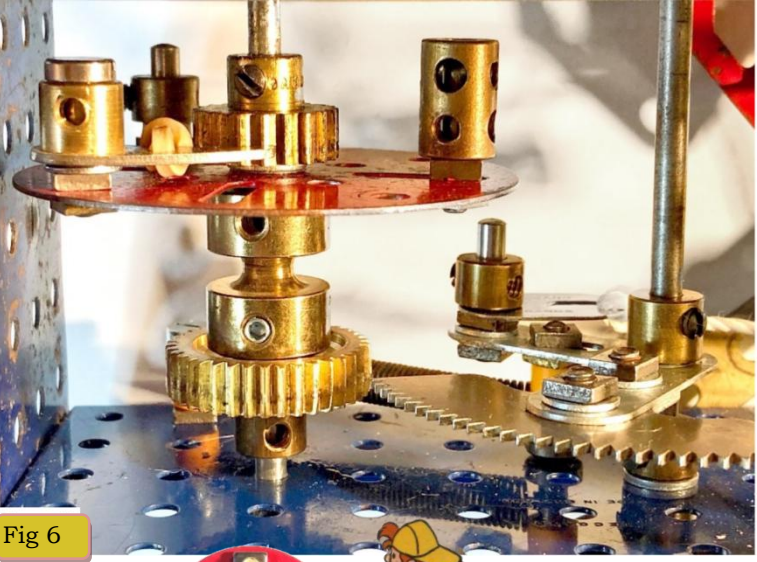
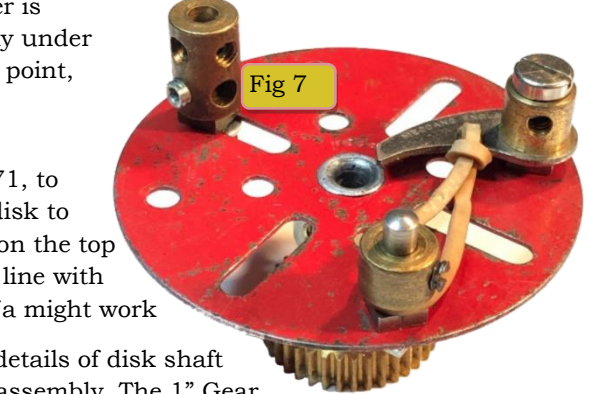
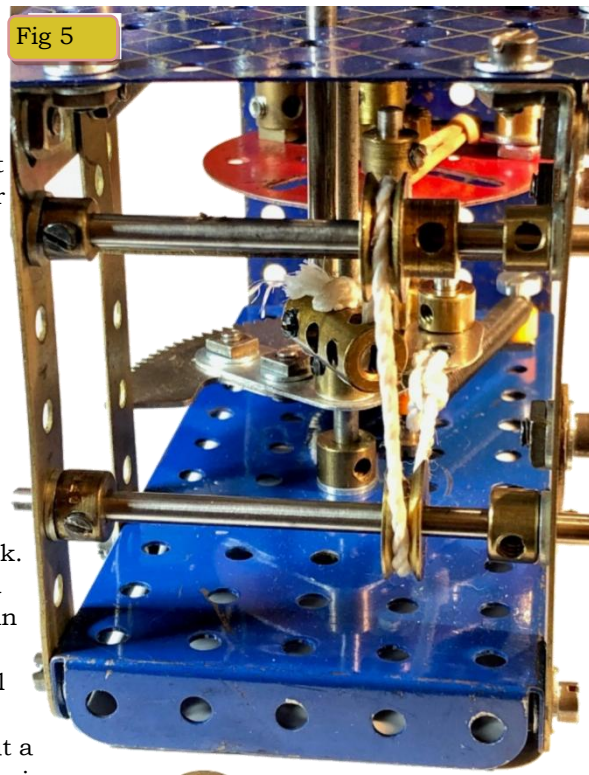
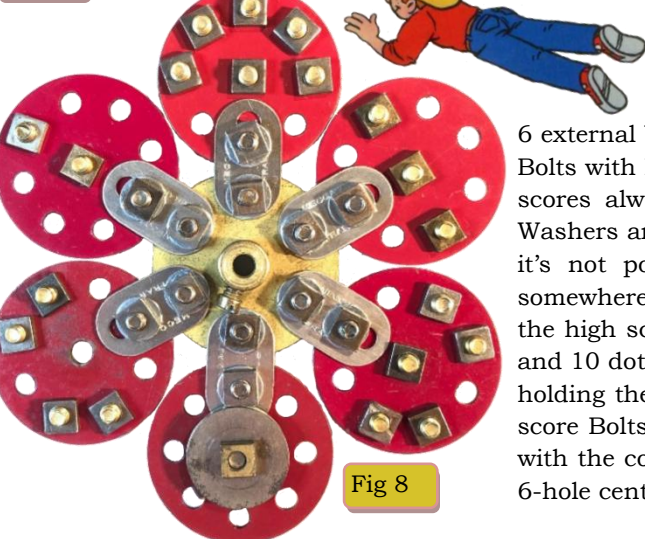


Fig. 6 shows the details of disk shaft and freewheeling assembly. The 1" Gear and Faceplate are joined by the Socket Coupling but are left running free on the shaft. A Pawl fitted on a Pivot bolt (spaced with a Collar above, and with a Washer below), engages with a Ratchet Wheel which is firmly fixed to the disk shaft. The Faceplate/Coupling/1" Gear assembly is held at the correct height by a Collar beneath, with a Washer over to help free running. Careful running adjustment and some light lubrication is required so that the Faceplate assembly will spin independently from the disk shaft to allow the disk to free run easily while still allowing the Segment arm to return to its rest position.

Fig. 7 shows details of the Faceplate. A lightweight elastic band hooked on a Threaded Pin (or lightweight Tension Spring if you have a suitable size) engages the Pawl with the Ratchet Wheel. A short Coupling on the other side of the disk helps balance the assembly – noticeable vibration is readily apparent if you don't fit this. Any Meccano parts will do as long as they counter-balance the weight of the Pawl, Pivot and elastic band anchor pin.



The die score wheel. This uses a 6-hole Bush Wheel at its centre to allow 6 external Wheel Discs that represent the die scores. The scores are indicated by brass Bolts with Meccano Washers under, and the scores disks are arranged so that opposite scores always add up to 7, just like real dice! Again, balance is important as the Washers and Bolts weigh quite an appreciable amount. A die has a total of 21 dots, so it's not possible to balance this on a circular disk without adding extra weight somewhere. With the disk score arrangement defined by the rule of "7" and distributing the high scores equally every 120°, the completed disk has 11 dots on one half sector and 10 dots on the other. Adding a pile of three 38d Washers under the 3/8" Bolt head holding the score Washer "1" helps allow the disk to be balanced statically. The other score Bolts are standard 7/32" length. Fig. 8 shows the reverse side of the score disk with the counterbalance Washers and how the 8-hole Wheel Discs are attached to the 6-hole central Bush Wheel. For the magnet to work it's essential that the 8-hole Wheel Discs are the painted steel type and not brass!



Win your sweeties here!

Fix the score marker to the top Plate, a 1" Corner Bracket, spaced to the height of the disk by 2 Collars and fixed only at one corner by a 3/4" Bolt. A decorative Bolt is fitted to the other corner purely for symmetrical looks! The score disk Magnet, a recent Meccano round ferrite Magnet part 537a is held in a Coupling which itself is fastened to a Threaded Pin attached to the top Plate. This arrangement allows height, position and spacing of the Magnet to be adjusted so it can centre the Wheel Disc score with the score marker, and just about clear the disk when it is spinning. The closer you can get the Magnet to the Wheel Disc, the more effective it will be! A brisk firm push on the plunger should set the score disk spinning anti-clockwise, and it will come to rest after approximately 5-6 seconds to show your "score". During this time, the free-wheeling Faceplate will spin for some time in the opposite sense as the Segment is pulled home by the Tension Spring and give rise to a rewarding bicycle-like ratchet noise! The model could be a divertissement at a Meccano Exhibition and small sweet prizes could be given to youngsters and oldies scoring double-sixes or triple twos etc!



Fig 9

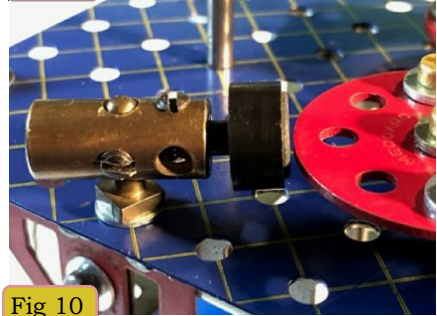
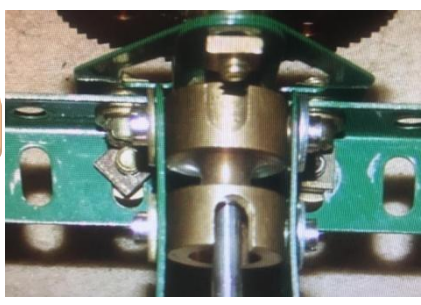
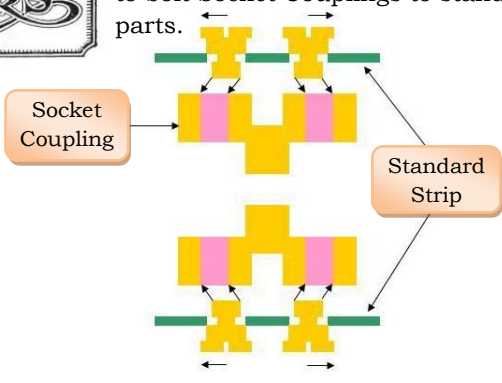


Fig 10

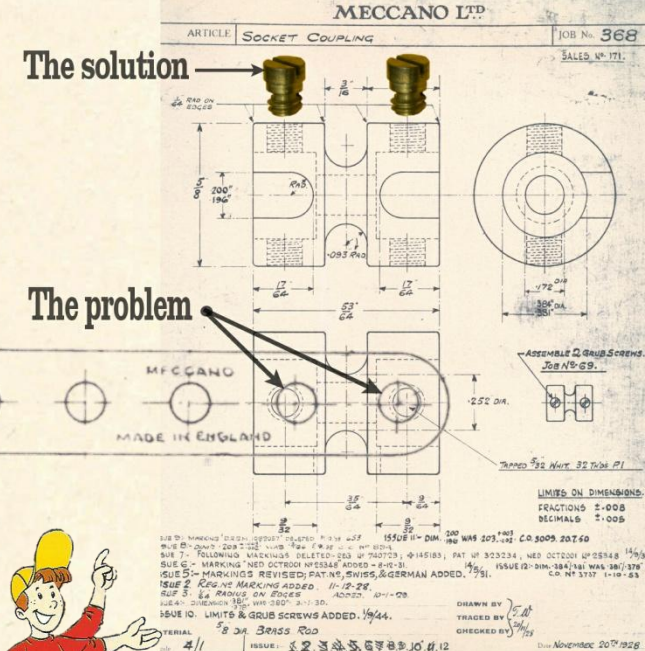
FROM OUR READERS

Richard Payn from the UK tells us about a way to bolt Socket Couplings to standard 1/2" spaced parts.



How to bolt a Socket Coupling to a standard Meccano Strip via its tapped holes, which are slightly further apart than 1/2".
 Use Shoulder Bolts from Universal Couplings. The undercut enables them to be moved sideways, so that the bolt threads match up with the tapped holes of the Socket Coupling, when inserted through the holes of a standard Strip. A standard Meccano Washer is fitted under the bolthead to get the undercut in line with the Strip hole edge.

You can see the original blueprints for Meccano parts on Tim Edwards' website or just click on the blueprint photo to the left.



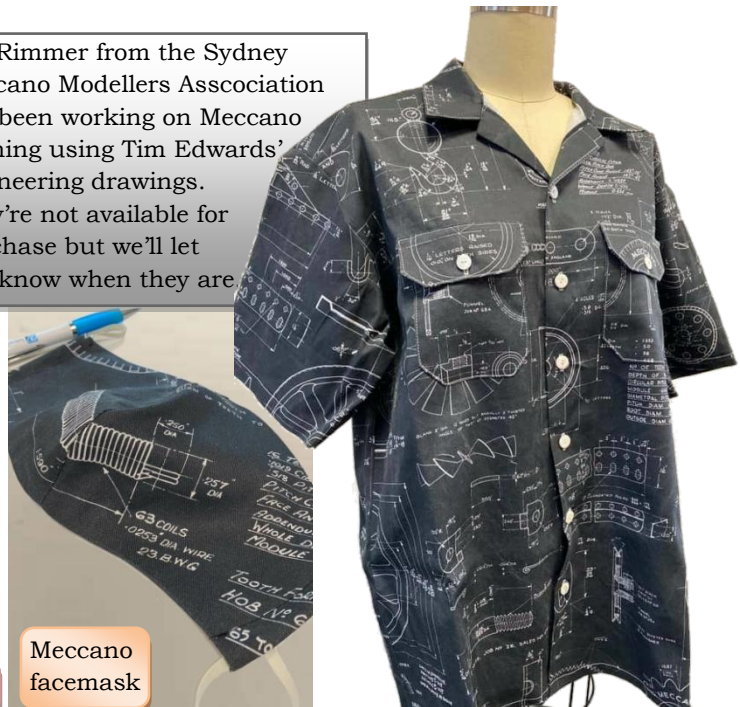
<https://meccanoindex.co.uk/Drawings/Index.php?id=1595398835>



I used my pay to buy this for Johnny. It's educational.

I'm about to educate you

Joe Rimmer from the Sydney Meccano Modellers Association has been working on Meccano clothing using Tim Edwards' engineering drawings. They're not available for purchase but we'll let you know when they are



Meccano facemask

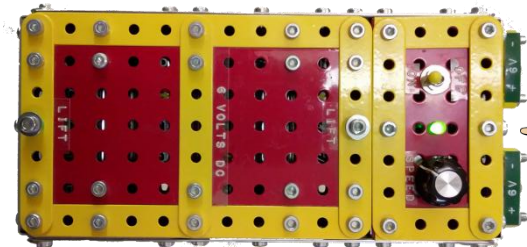
This Month's Meccanoboy

Doug Trounce - Dubbo

Australia



Doug's
unique style



I first met Doug at the Sydney Expo in 2017 and was most impressed with his colourful models and control boxes complete with Dymo labels! Doug doesn't do Spanner or Rustbucket but his daughter recently showed him how to use Facebook to communicate with fellow Meccanoboy's. I called him on the phone and put him through the 3rd degree.

When and where were you born.

Dubbo, NSW, 1952 which makes me 68 and I've lived in Dubbo for my whole life.

Did you do all your schooling in Dubbo?

No. In 1964 I went to a boarding school in Sydney called the Sydney Church of England Grammar School or SHORE for short as it's located on the North Shore of Sydney. One of my jobs was the flag monitor and I had to raise the Australian flag to the top of a tall tower overlooking the quadrangle. I also remember some of the boys sneaking out at night to meet up with girls but I'm not admitting to that. Perhaps that ladder that was leaning against the wall was part of the escape plan. After I completed secondary school I went back to Dubbo to complete my degree in Land Surveying and Civil Engineering.

I understand you're retired now but what did you do for a living in Dubbo?

For 50 years I was a surveyor. It was a very stable and enjoyable career.



Did you get married and have kids?

Yes, I married my beautiful wife Jo-Anne in 1979 and we have one daughter, Shannon. Jo-Anne and I both grew up on farms in Dubbo. Jo-Anne's parents had a dairy farm on the outskirts of Dubbo and my parents had a large multipurpose farm out of town that had sheep, cattle and wheat plus whatever other seasonal crops were viable at the time.

What was your first Meccano Set?

I remember it well. It was a Number 4 outfit that was given to me on my 8th birthday. My 1st model was the windmill from this outfit and I've been hooked on Meccano ever since.

Do you have any other hobbies or sports?

Well, there is LEGO but don't tell anyone. I love playing social tennis.

What were some of your more memorable models?

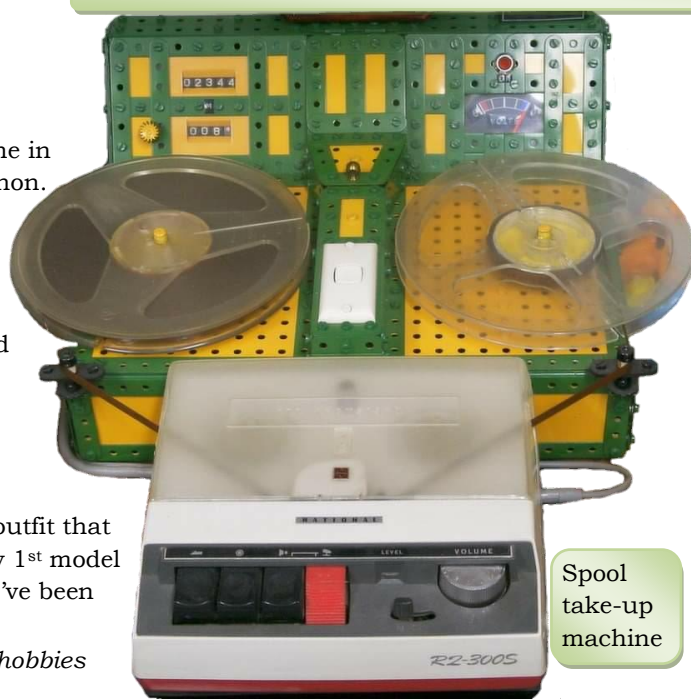
When I was 18 I built a take-up machine for my reel-to-reel tape recorder. I needed a way to play my 7 inch spools on my 3 inch tape recorder/player so I built this unit to take up the slack as the tape passes through the player.

Dubbo is a fairly isolated farming community in the middle of the country. Where did you buy your Meccano in such a remote town?

Well the local newsagent stocked it. I was a regular customer. Probably the only customer! When I was about 18 I got a phone call from John Morgan who owned the toy shop. He had a Ten Set that no one was interested in and as I was probably the only Meccanoboy within a hundred miles he offered it to me at the reduced price of \$299. I jumped at the chance! Later on I bought another Ten Set from Hobbyco in Sydney that had the aluminium handles. As you can see in some of my photos, I have replaced the white knobs and aluminium handles with brass knobs.

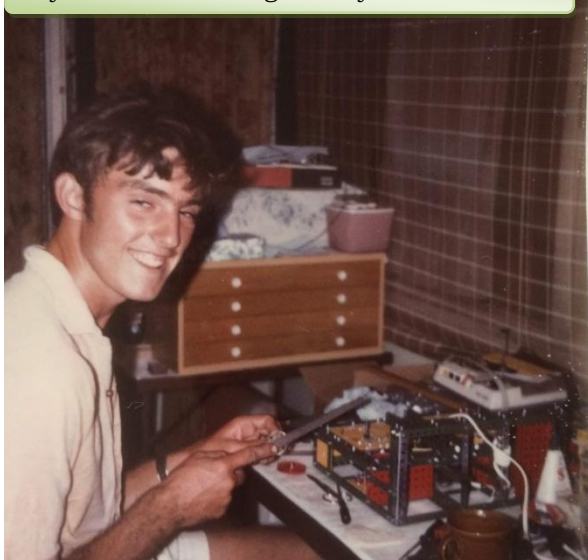


SHORE Grammar School in the 60s. See the ladder?



Spool take-up machine

18 years old and Doug already has a Ten Set!



Have you ever been to Meccano expos overseas?

No. I have travelled along the West coast of America but no Meccano shows. In fact the only place I've ever exhibited my models is at the Sydney Expo. I went on a cruise ship around New Zealand. It was one of the Princess liners but not the Ruby Princess! (Ed note: The Ruby Princess was the COVID-19 infected liner that everybody was allowed to disembark from in Sydney recently).

At the Sydney Expos I've noticed most of your models are very colourful and appear to be made from modern French powder coated parts. Where did you get all those parts?

When I saw the Ferris Wheel outfit I was so impressed with the colours I went out and bought 29 outfits! Many of them were discounted and I just can't resist a bargain.

What was your first car?

A Morris Oxford that I made up from two broken down cars in Dubbo when I was 18. I'm sure my Meccano prowess helped in that regard.



What do think of the direction Spin Master are taking since they took over the Meccano brand.

Well the Tower Crane was good even though it had a problem with the angle girders that didn't fit and I thought the Eiffel Tower was pretty good with the 1/4" hole spacing but you really need 2 outfits to build a decent sized model. Mike Holland built a double sized Eiffel tower and exhibited it at the Sydney Expo. The current lot of plastic stuff has just ruined the whole concept of Meccano though. I'm just not interested in it. The manuals are really bad with instructions that are impossible to follow.



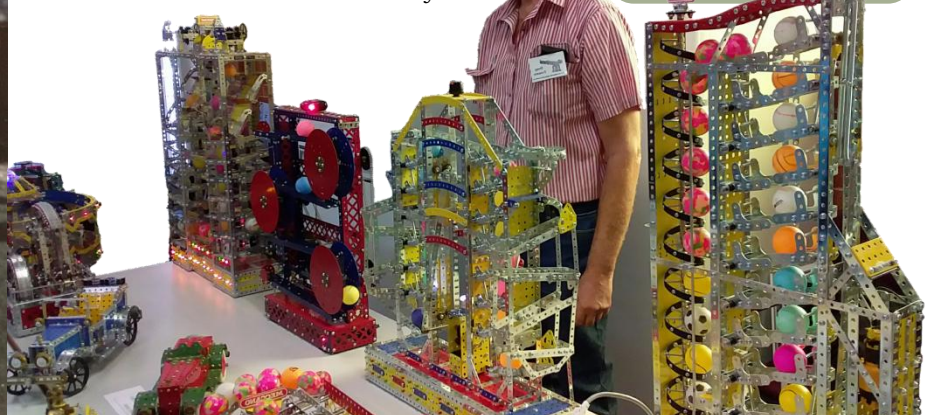
At home in Dubbo before my hair turned grey



How many Meccano exhibitions have you attended?

Well none really. Only the Sydney Expo that I enjoy at every opportunity. Dubbo has never had a Meccano club and I have always been a one man band as far as building Meccano in Dubbo is concerned. There are some members of the Sydney club who live in Tamworth but that's still 3 and a half hours drive away.

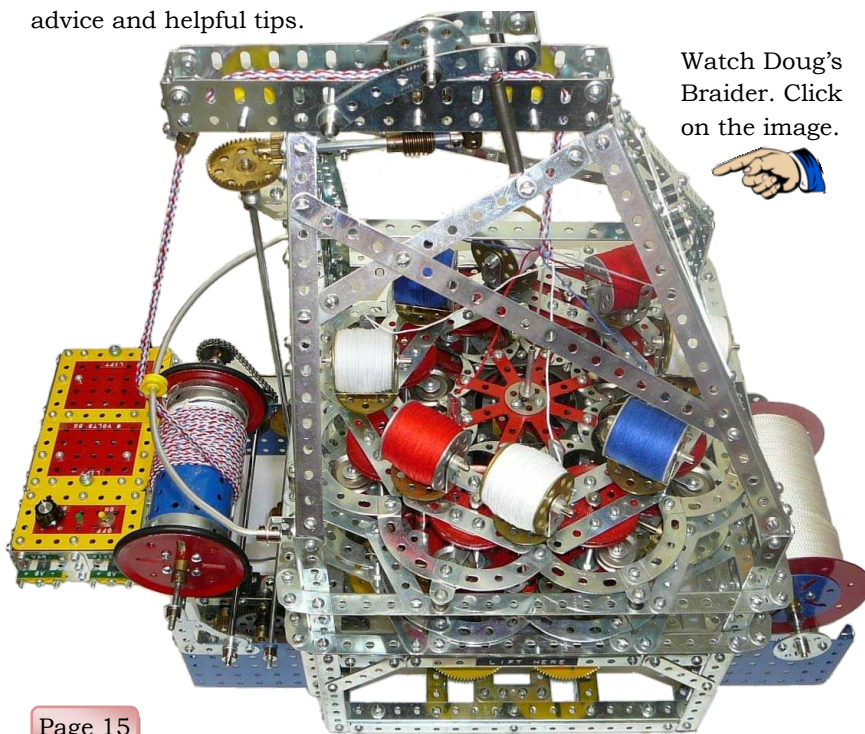
At the Sydney Expo in 2019. Sadly the 2020 Expo was cancelled due to COVID-19



Watch Doug's ball roller   <https://youtu.be/pgtcvvpAgBk>

My 8 spool, 3 colour braider was built from a detailed layout in CQ 81 Sep 2008 by Graham Jost. It had easy to see photos with clear descriptions of the inner workings. I had to ring Graham a few times with questions and he was always happy to help me out with great advice and helpful tips.

Watch Doug's Braider. Click on the image.





A few of my favourite things.

We are John & Johnny. A father and son team who like Meccano. We're nothing to do with Spin Master who own the brand. Contact us at MeccanoNews@gmail.com Follow Johnny Meccano



New Zealand

<http://www.nzmeccano.com>

<http://www.nzfmm.co.nz>

<https://www.facebook.com/MWT-Meccano-Club-1476153515979522/>

Australia

<http://www.mmci.com.au>

<http://www.sydneymeccanomodellers.org.au>

<http://www.webjournalist.com.au/maylands/index.html>

South Africa

<https://www.facebook.com/Meccano-Club-of-South-Africa-464753870326296>

USA and Canada

https://www.spinmaster.com/brand.php?brand=cat_meccano

<https://www.usmeccano.com>

<http://www.meccano.com>

<http://www.cmamas.ca>

<http://www.bcmeccanomodellers.com/meccano-in-canada.html>

<http://www.meccanoquebec.org/index2ang.html>

UK

<http://www.internationalmeccanomen.org.uk>

<https://londonmeccanoclub.org.uk>

<https://tims.org.uk>

<http://hsme.org.uk>

<https://nelmc.org.uk>

<https://runnymedemeccanoguild.org.uk>

<https://www.selmec.org.uk>

<http://www.hsomerville.com/wlms>

<http://www.midlandsmeccanoguild.com>

<https://southwestmeccano.org.uk>

<http://www.northwestmeccano.co.uk>

<https://northeasternmeccano.org.uk>

<https://www.meccanoscotland.org.uk>

<http://www.corlustmeccanoclub.co.uk>

<https://nmmg.org.uk>

Personal pages

<https://www.alansmeccano.org>

<http://www.users.zetnet.co.uk/dms/meccano>

<http://www.dalefield.com/meccano/index.html>

<http://www.meccano.us>

<https://www.meccanoindex.co.uk>

<http://www.meccanokinematics.net>

Other Countries

<http://club-amis-meccano.net/>

<http://www.meccaninfos.com.ar/>

<http://www.meccanogilde.nl>

<http://meccano.free-bb.fr/>

<https://www.aceam.org/es/> **NEW!**

Meccano suppliers

<http://www.meccanohobby.co.uk>

<http://meccanoman.co.uk/catalog>

<https://www.meccanospares.com>

<https://ralphsshop.com>

<http://www.hsomerville.com/mwmailorder>

<http://www.metalconstructiontoys.com>

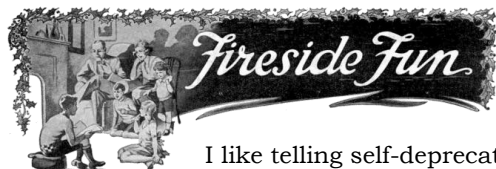
<http://www.meerlu.com.au/>

<https://tinyurl.com/AshokBanerjee>

sales@meccgear.co.nz



MeccGear Jeff Clark New Zealand jeff@kjd.co.nz No website yet but a pricelist with photos can be downloaded here



I like telling self-deprecating jokes - but I'm not very good at it.

An older man, not in the best physical condition, asked the Trainer in the gym, "I want to impress that beautiful girl over there. Which machine should I use?" The trainer replied, "Try the ATM outside the gym!"

My neighbour knocked on my door at 2:30am this morning Can you believe that?? - 2:30am! Luckily for him I was still up playing my Bagpipes - PJM

"Doctor! You've got to help me! I accidentally drank some poison and I'm going to die in exactly 59 seconds!" "Don't worry - I'll be with you in a minute!" - RiotMachineMark5

Reaching the end of a job interview, the HR manager asked the young engineer fresh out of university, "And what starting salary were you looking for?" The engineer said, "In the neighbourhood of \$100,000 a year, depending on the benefits package." The HR Manager said, "Well, what would you say to a package of \$200,000 a year, 5 weeks of vacation, 14 paid holidays, full medical and dental, company matching retirement fund to 50% of salary and a company car leased every 2 years - say, a Mercedes?" The engineer sat up straight and said, "Wow!!! Are you joking?" The HR Manager said, "Of course...but you started it."



Send your jokes to MeccanoNews@gmail.com

This virus has done what no woman has been able to do. Cancel all sports, shut down all bars and keep men at home.