



April 2022

In this issue

Buy me a coffee

<https://ko-fi.com/johnnysmeccanomagazine>

We have a Meccanogirl!



Mary Jost

Page 13

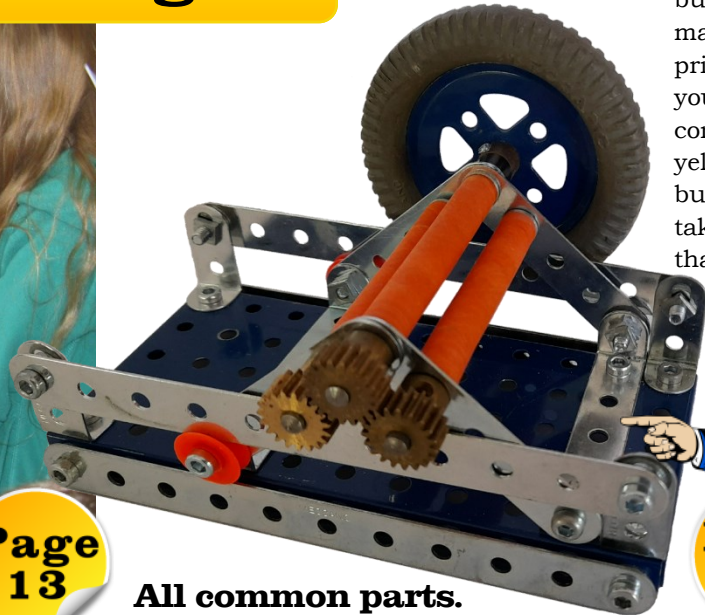

Build this

Page 2

All common parts.

Plate Roller For The Common Man

On the road
Melbourne

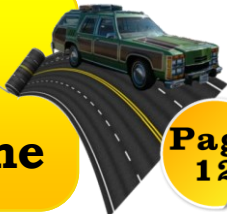

Page 12

GOOD IDEAS

Page 11



Page 16

Stan Knight does it again
Build the Magic Roundabout

Page 9



Page 1

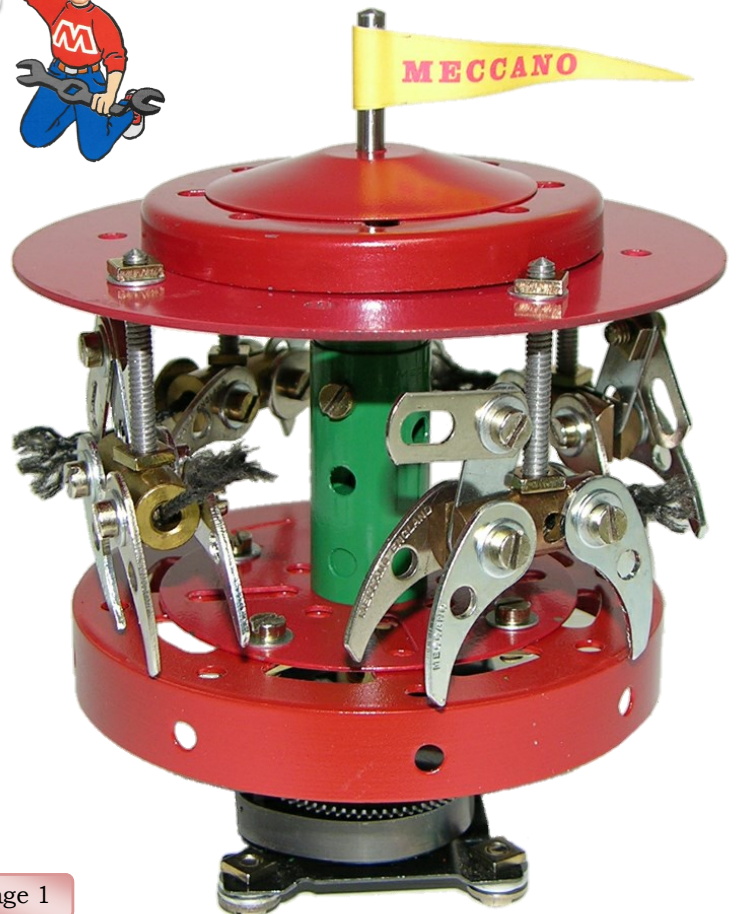
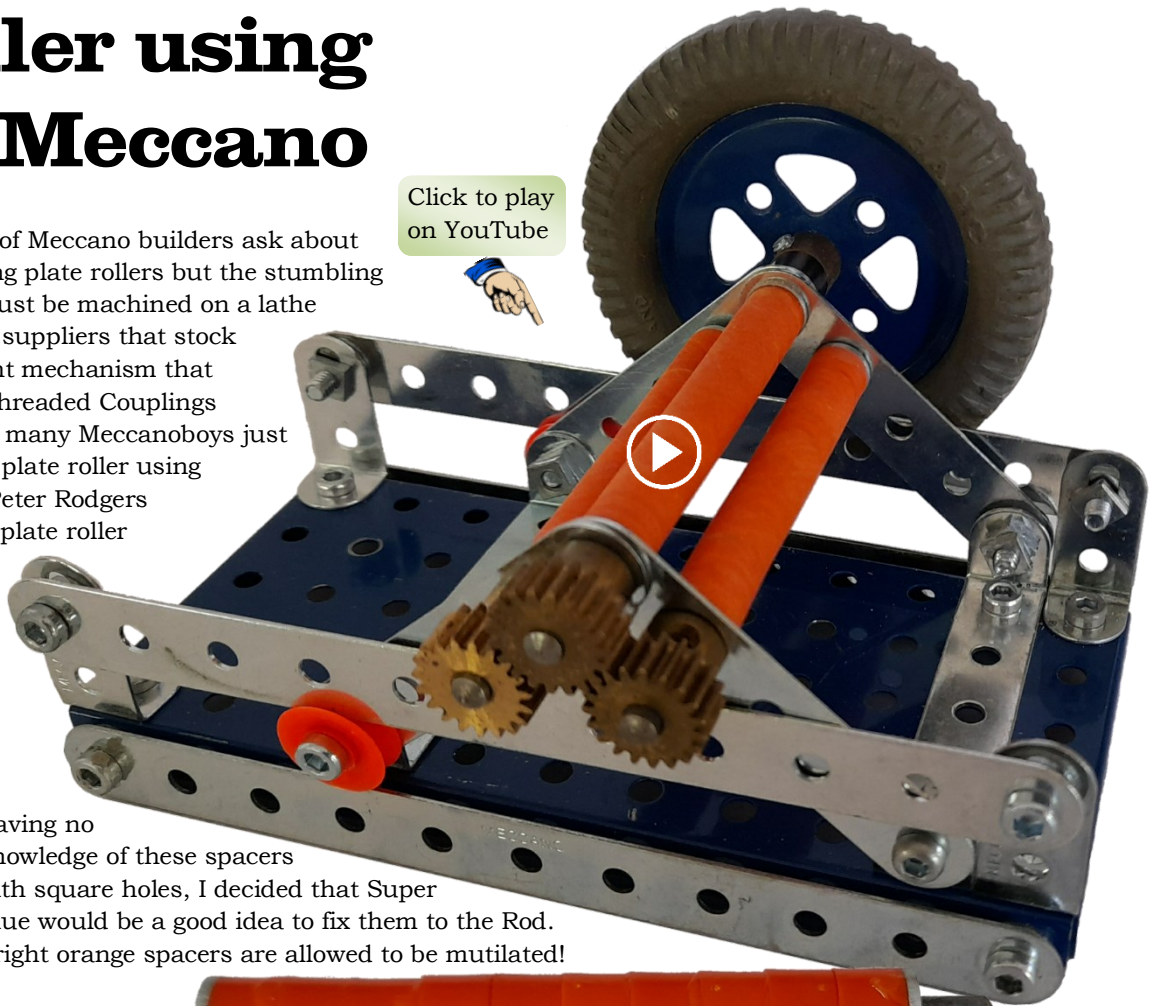

Plate Roller using common Meccano parts.

A lot of Meccano builders ask about making plate rollers but the stumbling block is always the rollers that must be machined on a lathe or purchased from one of the few suppliers that stock them. Then there's the adjustment mechanism that usually involves Screwed Rods, Threaded Couplings and Cranks. These are parts that many Meccano boys just don't have. My mission: Design a plate roller using everyday parts that we all have. Peter Rodgers from the IOM, UK made a simple plate roller using plastic spacers but he said they weren't glued but rather they had square holes that made them tight on the Rod.

Click to play on YouTube



Having no knowledge of these spacers with square holes, I decided that Super Glue would be a good idea to fix them to the Rod. Bright orange spacers are allowed to be mutilated!



Before



After

BluTac prevents the Super Glue running down the Rod. Use gloves!



The trick to get a nice flat rolling surface is to spin the rollers in a drill while holding a piece of sandpaper against them. The adjustment is made by sliding the two plastic pulleys between the 11-hole Strips. The top Strips are adjusted to apply downward force on the Pulleys which in turn puts downward pressure on the DAS causing enough friction to keep it in place.

Use coarse sandpaper to get the Spacers flush and smooth. Don't go too far!



All four 11-hole Strips have 2 Washers to bring them out for correct spacing.

Oops. Use longer Bolt.

Important! You must have a Washer at each end of the rollers to allow a 2.5" Plate to pass between the 5-hole Strips.

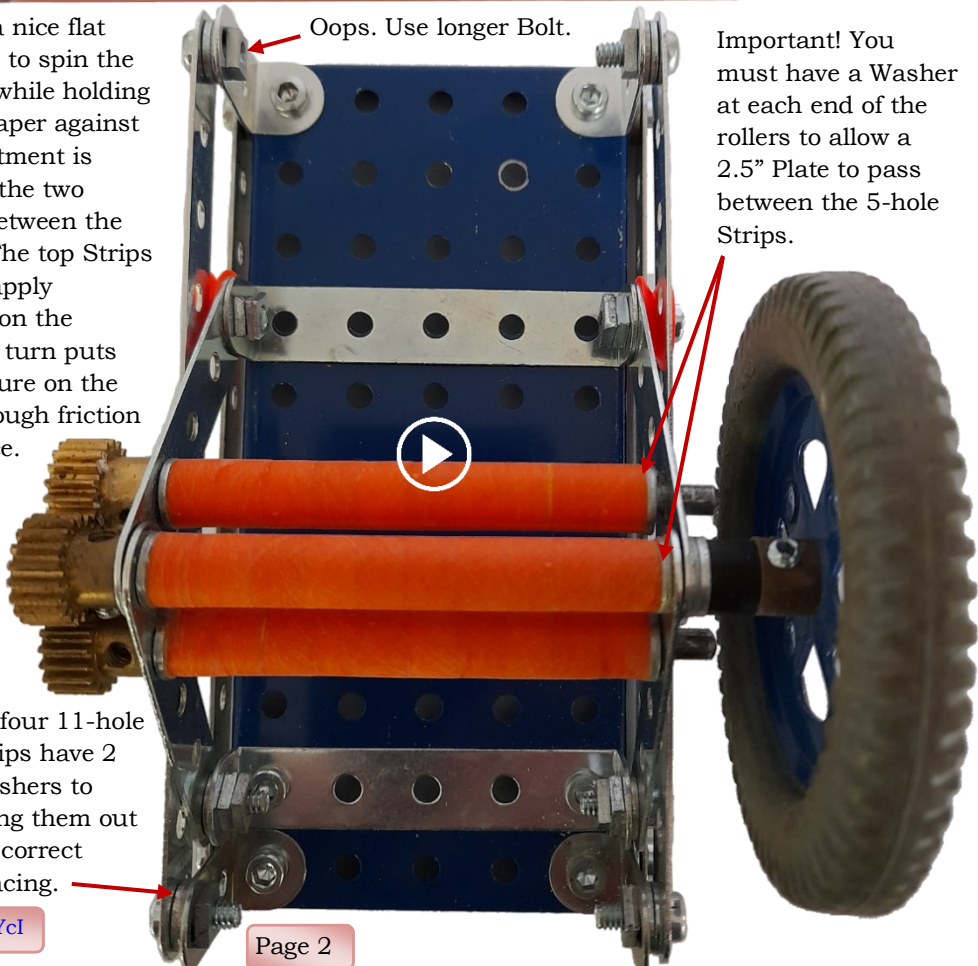

<https://youtu.be/wwwkkuB6Ycl>



Ed Veiga from Rio De Janeiro in Brazil LOVES Virtual Mec. He kindly produced all these accurate drawings.

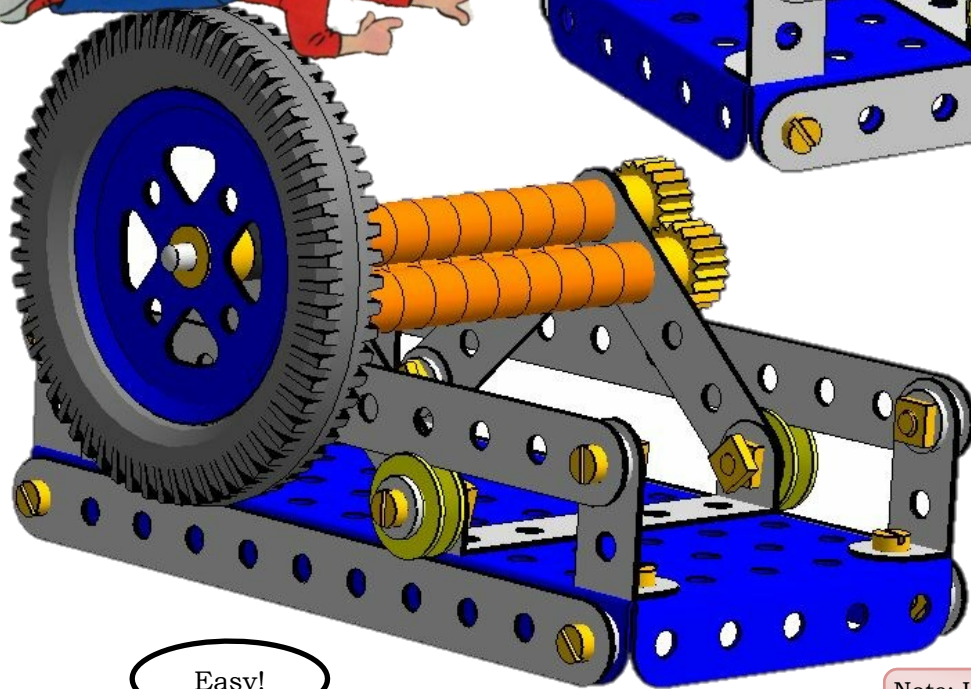
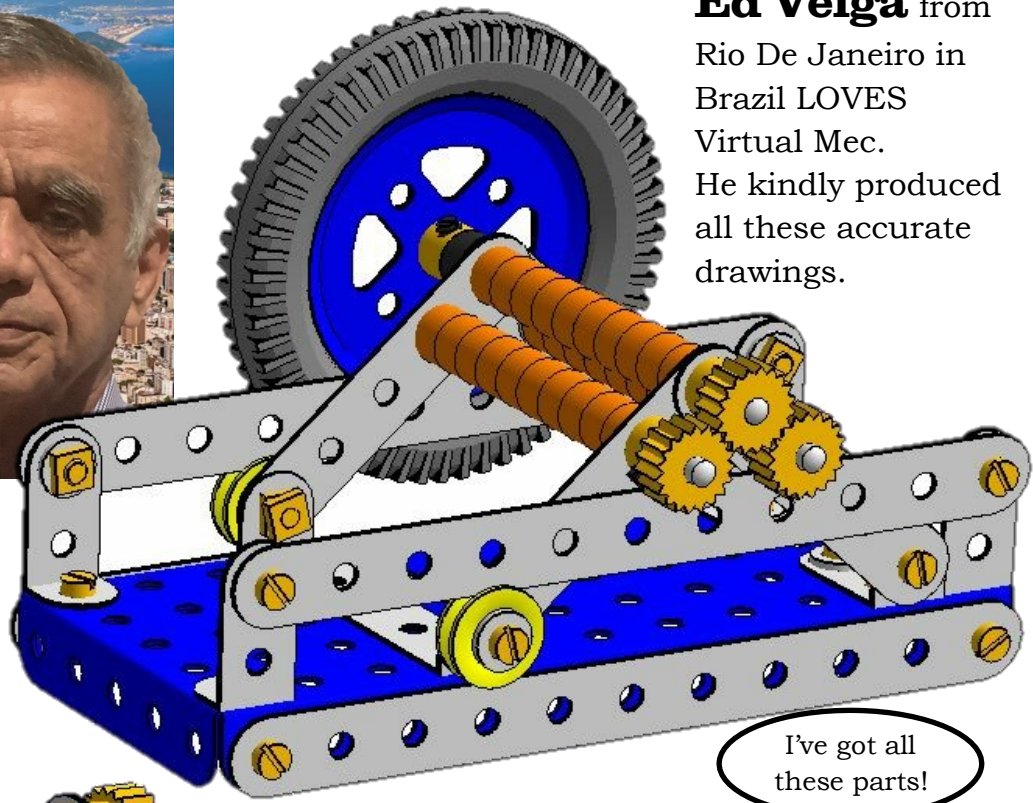

I've got all these parts!

Part No.	Description	Qty
2	Strip 5½"	4
5	Strip 2½"	4
12b	Angle Bracket	4
16	Rod 3½"	1
16b	Rod 3"	2
20a	Pulley 2"	1
23bp	Plastic Pulley	2
26	Pinion 19t	3
38a	Plastic Spacer	31
48a	Double Angle Strip	2
52	Base Plate	1
142a	Tyre 2"	1



Easy!

Note: I used a DAS but the 12b will do.

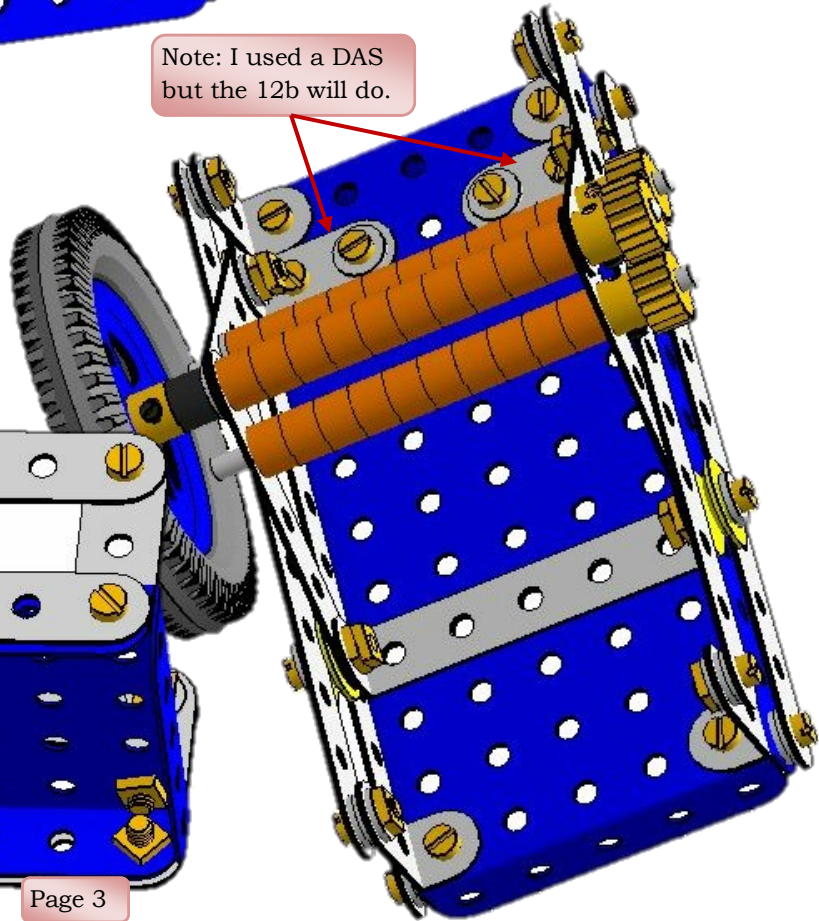
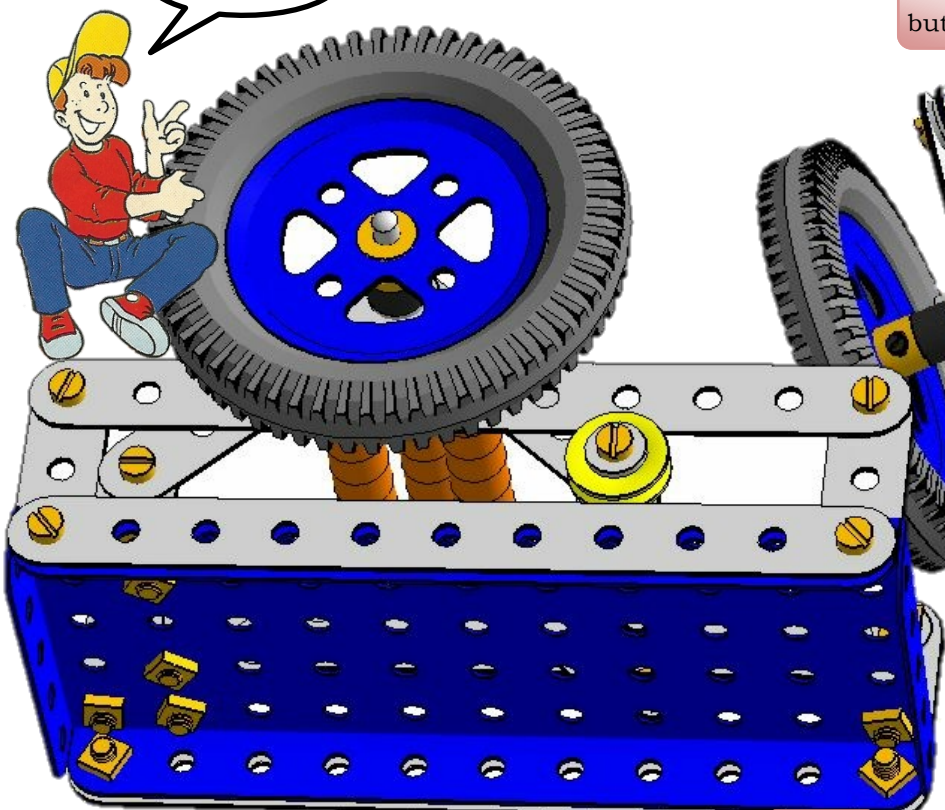

Build your own shield

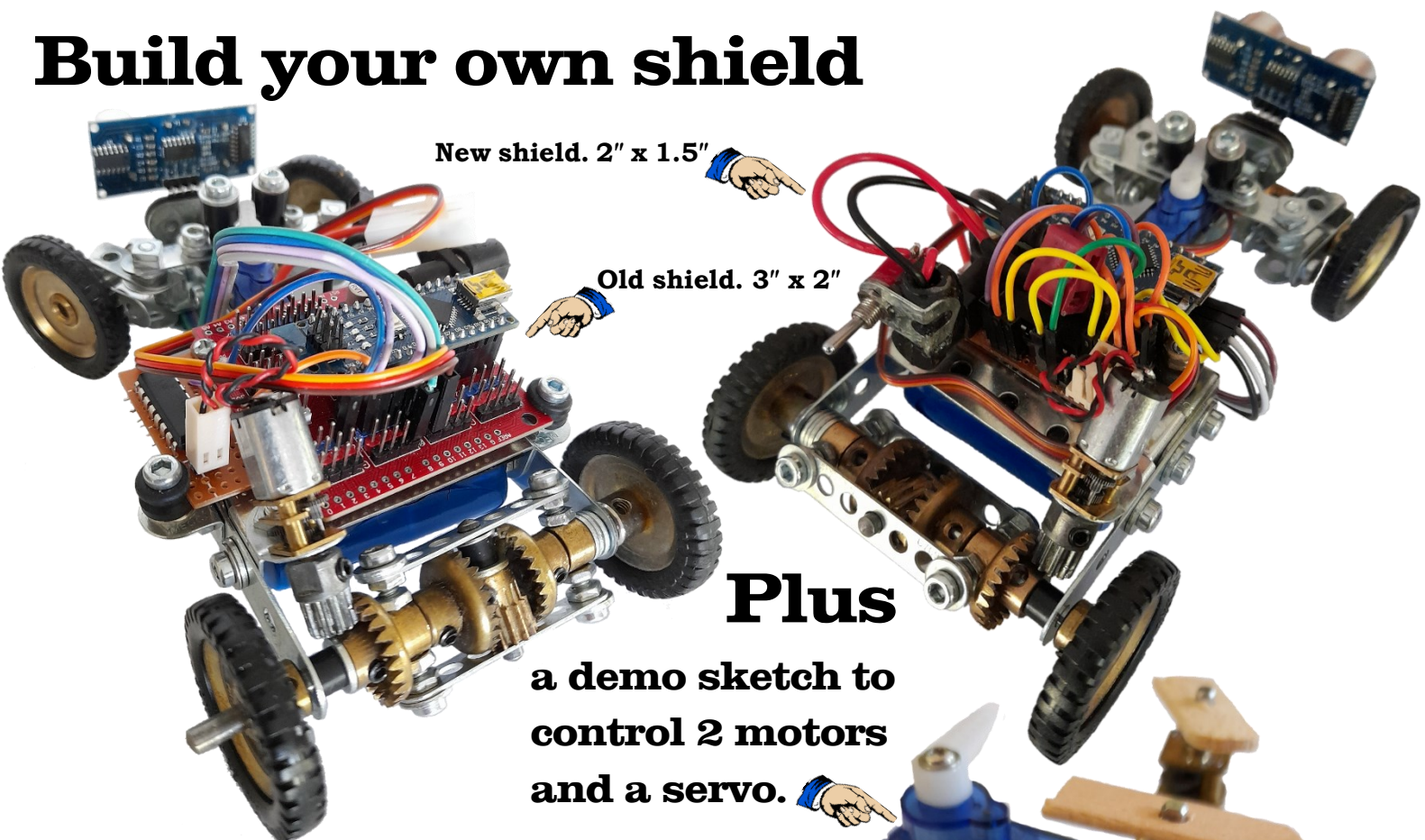

New shield. 2" x 1.5"

Old shield. 3" x 2"

Plus
a demo sketch to
control 2 motors
and a servo.

Most Arduino projects I've seen have two components: the sketch and the breadboard. Great for prototyping but if you want to use your creation in the real world you need to get past the breadboard and that means buying shields or in the case of most electronic magazine projects, buying a ready-made Printed Circuit Board.

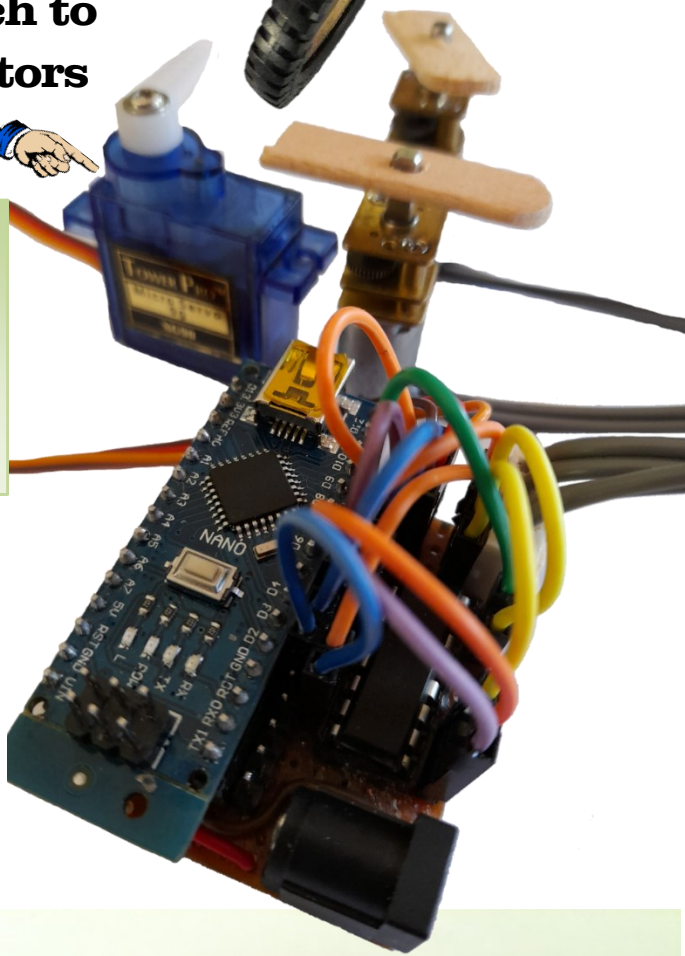
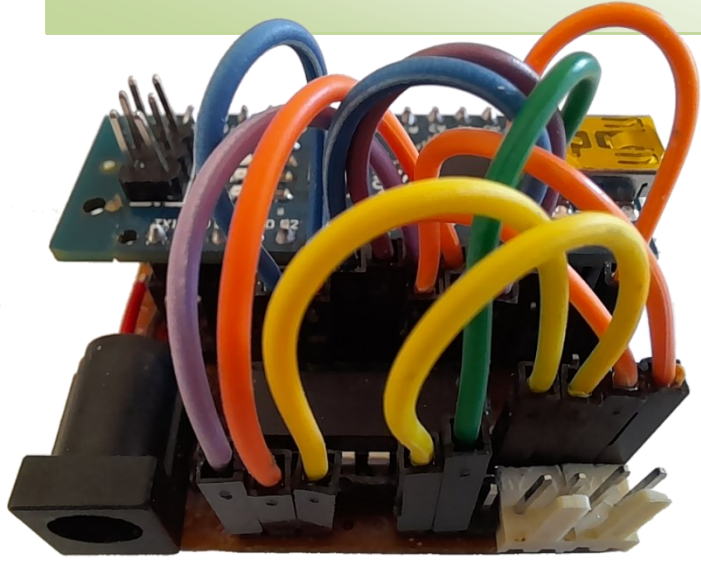

Maybe some expert makers can screen print or etch their own PCBs but even though I've got the Jaycar kit to do it, I've only tried once, and it wasn't easy. There's a middle ground solution; the Vero board. So, here's my latest project. Build a board that can drive 2 DC motors and a servo with the ability to swap out the Nano and H bridge and the versatility of moving jumpers around to suit.

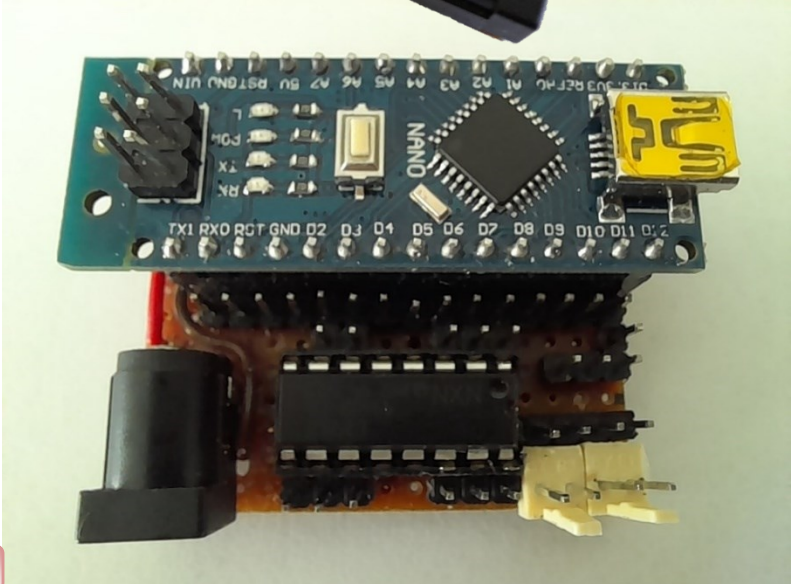

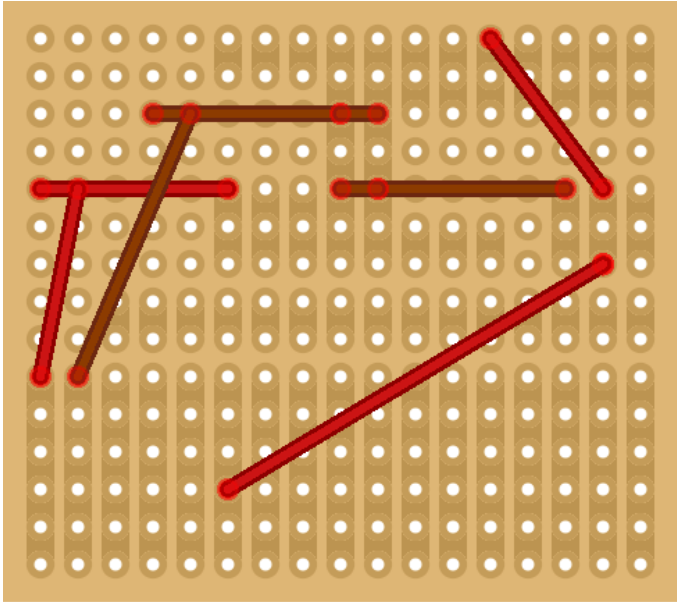

Cut out a Vero board of 17 rows and 15 columns. Use a blade to scratch off the unwanted track. I tried a Dremel, but it was a bit severe as you can see. Scratch out a 5x7 area to accommodate the 2.1mm DC socket. Then hard wire the positive to VIN of the Nano and Vcc 2 of the L293D H bridge.

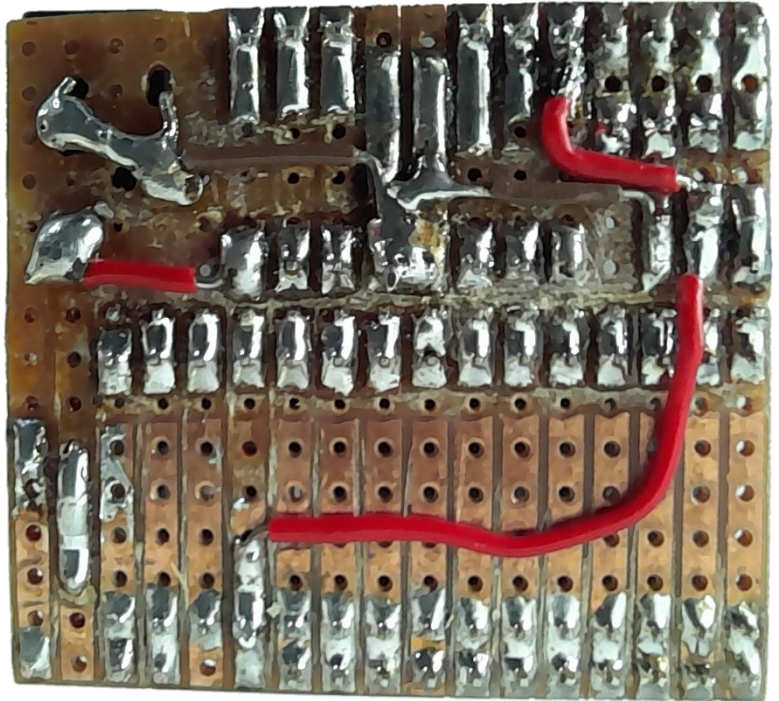

Hardwire the Earth to GND of the Nano, all four GNDs of the H bridge (pins 4,5,12,13) and to the GND of the servo header. Finally hardwire the 5v from the Nano to positive (centre) lead of the servo header and then to the Vcc1 Of the H bridge.

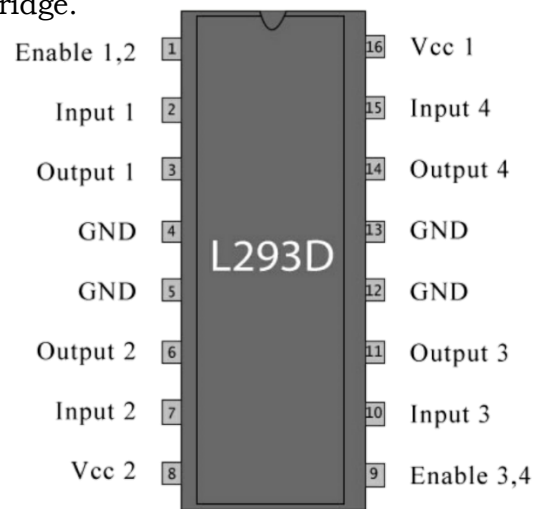
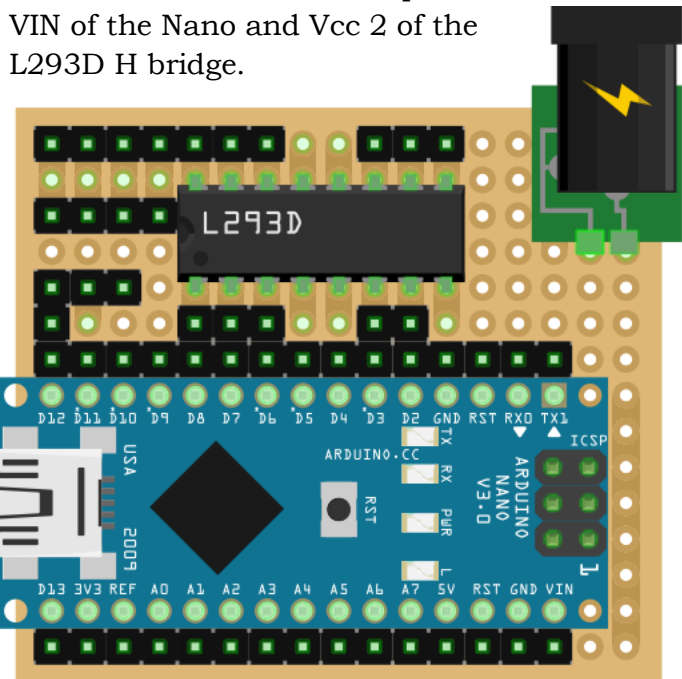

The Ground, +12V and +5V are the only connections that are hard wired. All other connections will be made by shortened jumper leads.

The photo to the right shows the positioning of the 15 pin Nano sockets with 11 header pins on the analogue side and 14 Header pins on the digital side. You only need 11 on either side but this was a prototype pic. Set your multimeter to continuity buzz and test every column to make sure there's no solder splashes bridging the tracks. Next, add header pins to the H bridge pins 1,2,3,6,7,9,10,11,14,15,16. We don't need the GND pins or the Vcc1 because they're hardwired underneath. Also add a single header pin to the control pin of the servo header as shown in the Fritzing above. Lastly add 2 header pins to each of the keyed motor headers so we can jumper to them.

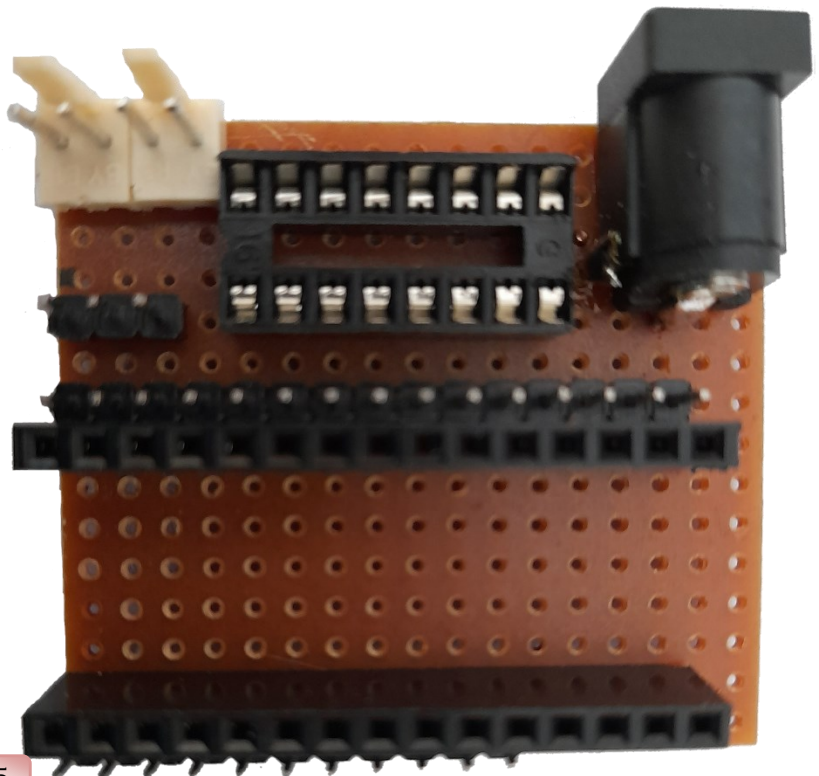

If your board looks like this, you're ready to add the jumpers but first check again with the meter. One invisible solder splash cost me a nano on the first try.

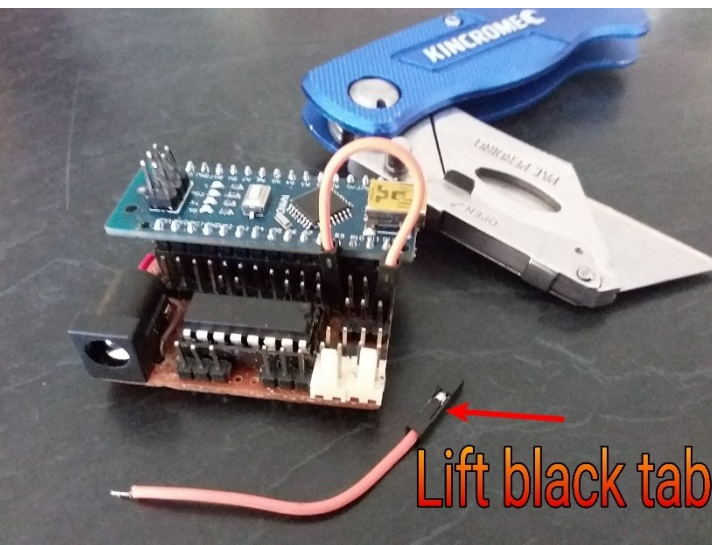
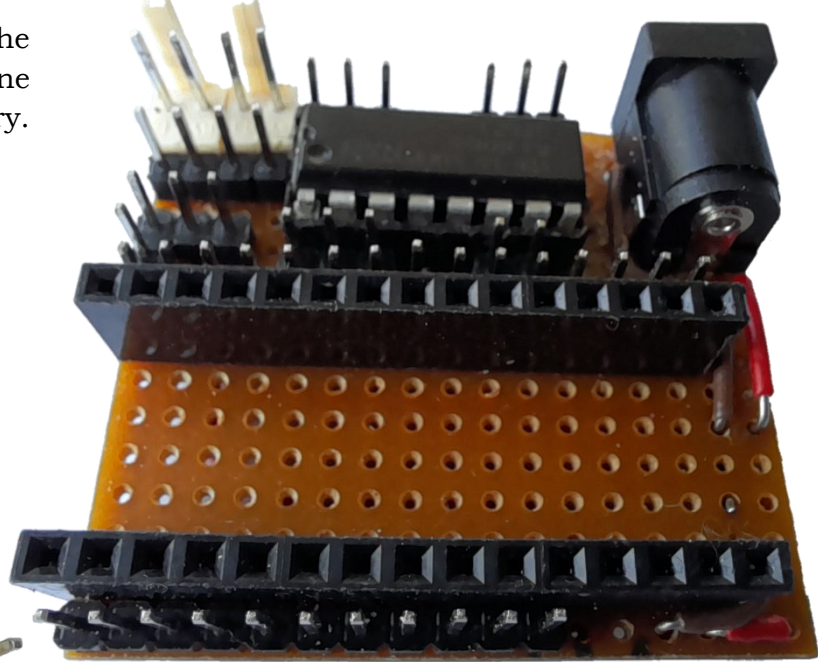
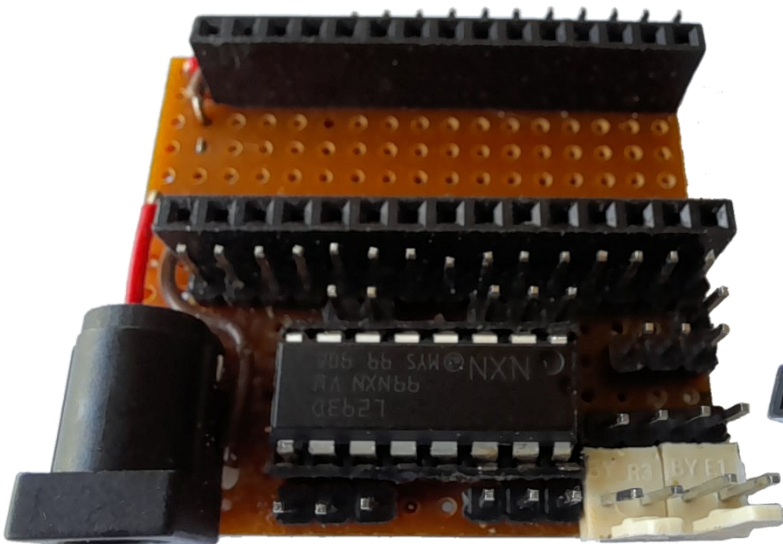

Dupont jumper leads are mainly found in 200mm lengths. By the time you make all the connections for this project you will have a giant rat's nest and lost one of the main reasons for building this shield which is to make it small. So, to make these short 70mm jumpers you need the knack.

Step 1.

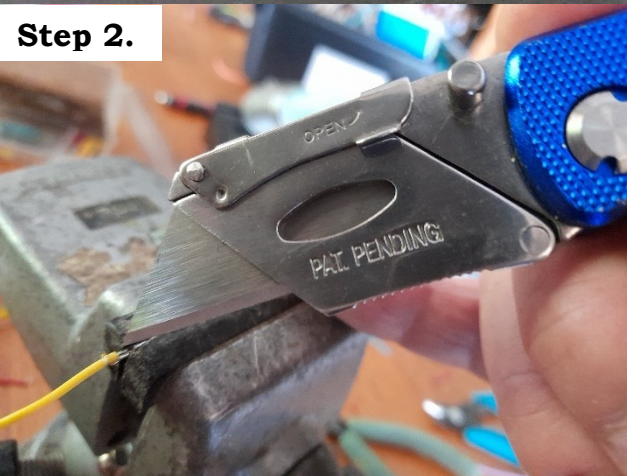

Step 2.

Step 1. Use a small screwdriver to lever up the black plastic tab and pull the wire out. Gently clamp it in the soft jawed vice making sure you keep the side with the clip upwards.

Step 3.



Step 2. A sharp Stanley type knife is best to lever up the crimp tabs that hold the insulated part of the wire. It's next to impossible to lever up the crimps that hold the actual wire, but I found every single one just pulled out anyway. Lightly tin the bare end of your shortened jumper lead. Be careful, too much solder and it won't slide back in under the crimps.

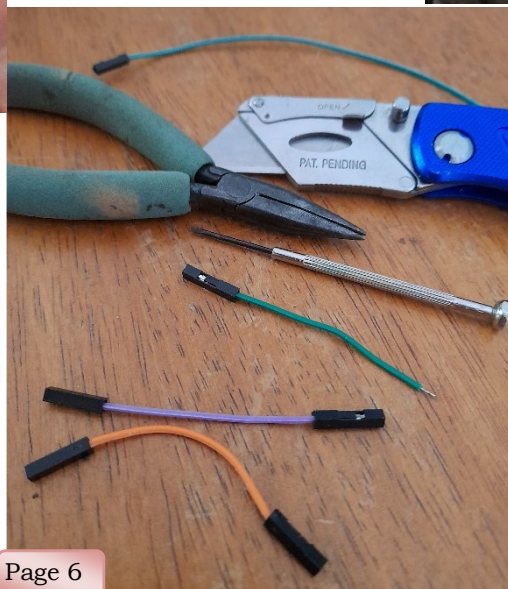

Step 3. Just for insurance, I quickly heated the crimp connector and then slid the wire in. Next, it's just a matter of closing the insulation crimps with needle nosed pliers and sliding it back into the black plastic housing. Make sure you push that black plastic tab back down so it will lock back into place.

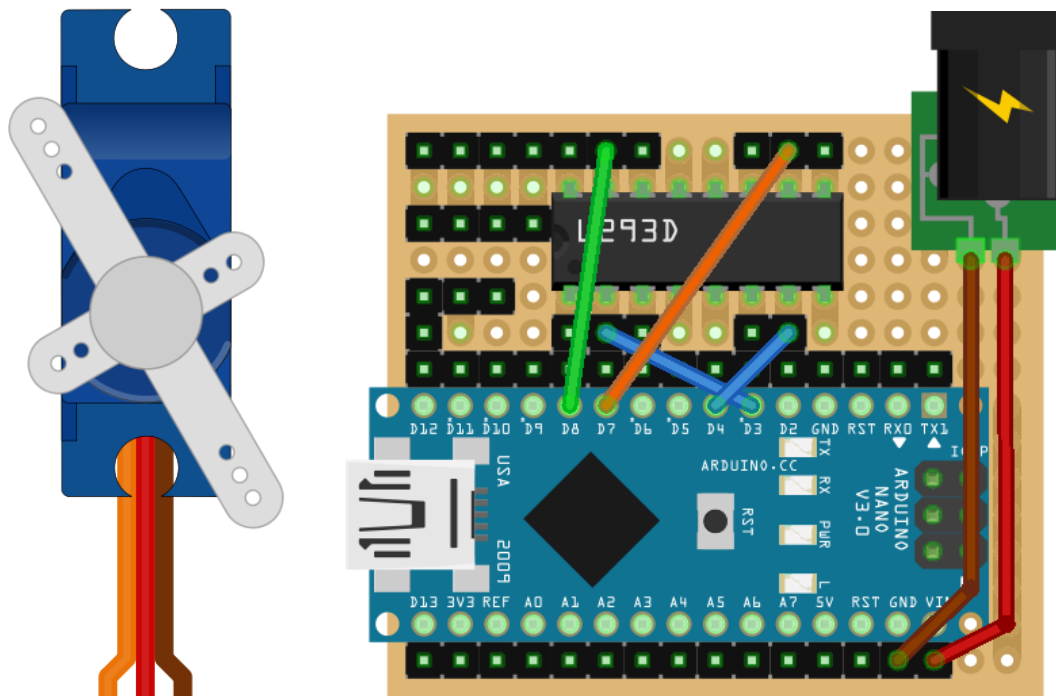

Fig. 1. The DC socket should be already hardwired. The H bridge inputs leads are:

- D3 to IN1
- D4 to IN2
- D7 to IN3
- D8 to IN4

With so many jumper connections it's not possible to show them all at once on a Fritzing diagram so I've drawn the steps in stages.

1. H bridge inputs.
 2. Servo and PWM leads.
 3. Motor outputs.
- Put them all together and don't forget we're dealing with two different voltages here. 12V for the motors and 5V for the H bridge Vcc1 and the servo control. I know they can take 6V but 5V works OK.

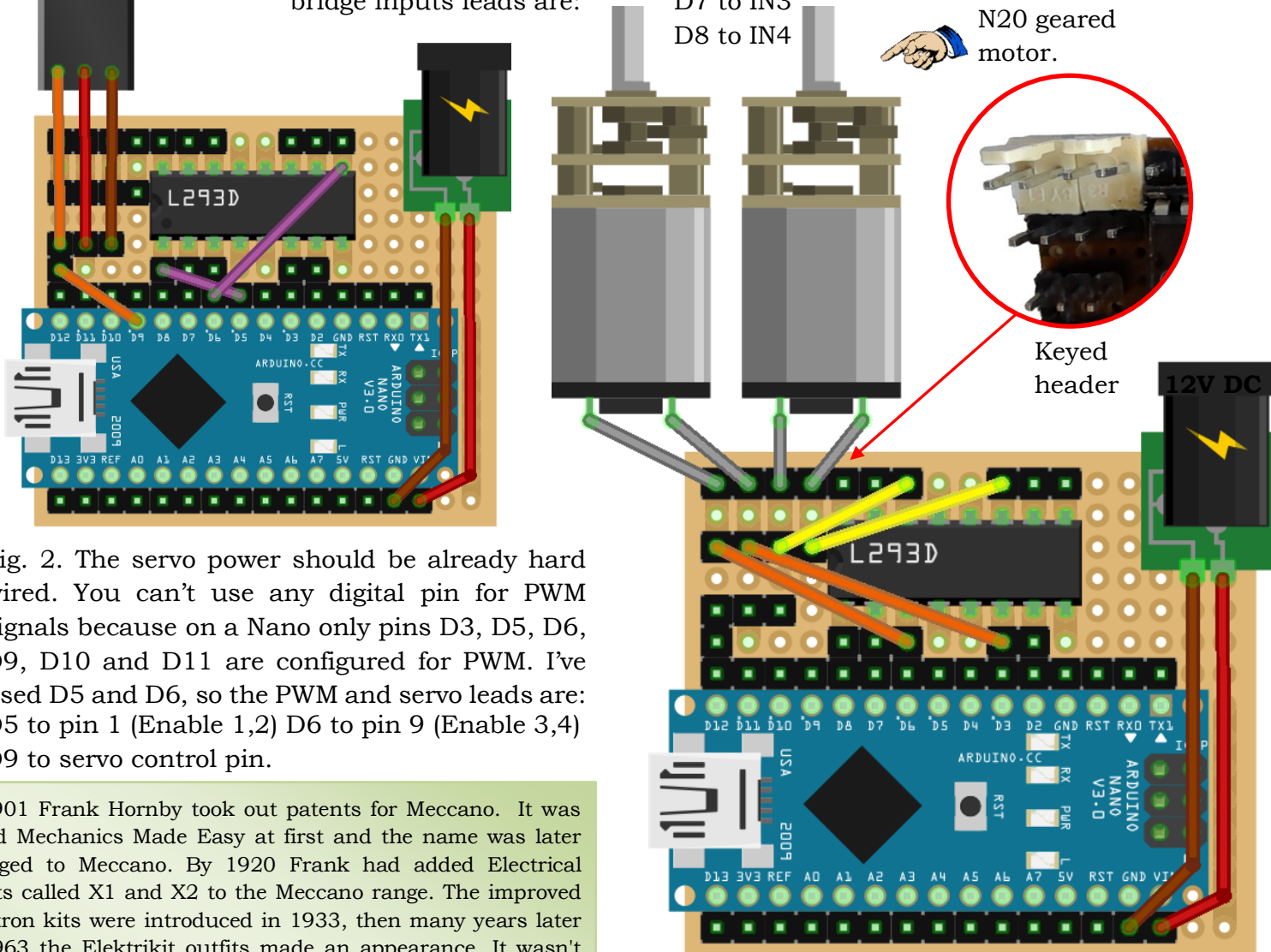

Fig. 2. The servo power should be already hardwired. You can't use any digital pin for PWM signals because on a Nano only pins D3, D5, D6, D9, D10 and D11 are configured for PWM. I've used D5 and D6, so the PWM and servo leads are: D5 to pin 1 (Enable 1,2) D6 to pin 9 (Enable 3,4) D9 to servo control pin.

N20 geared motor.

Keyed header

12V DC

Fig. 3. You could simply connect the motors to the header pins for the H bridge but it's neater and safer to use a keyed header to ensure you have forward and reverse correct. The motor leads are:
 Pins 3 & 6 to Motor A left.
 Pins 10 & 14 to Motor B right.

In 1901 Frank Hornby took out patents for Meccano. It was called Mechanics Made Easy at first and the name was later changed to Meccano. By 1920 Frank had added Electrical outfits called X1 and X2 to the Meccano range. The improved Elektron kits were introduced in 1933, then many years later in 1963 the Elektrikit outfits made an appearance. It wasn't immediately obvious to purchasers that the models pictured couldn't be built unless you also had a Meccano outfit as well so the 4EL outfit was produced which combined the Elektrikit outfit with the number 4 outfit. Over time electrics evolved into electronics with the advent of semiconductors and today, microcontrollers are used in conjunction with electronic components to control motors and lights etc in Meccano models. It's a natural progression that I'm sure Frank would have approved of. Meccano is more than mechanics.

Let's write a sketch.

We want to test both motors run forward and reverse as well as test the servo.

First step is to include the servo library. Let's call it myservo.

Now we tell the Arduino Nano microcontroller that the PWM pins we'll be using to control the speed are on digital pins 5 and 6 and called SpeedA and SpeedB.

The H bridge has 4 inputs so name them DirnA1, DirnA2, DirnB1 and DirnB2 and assign the digital pin numbers which are 3, 4, 7 and 8.

Now we've finished telling the Nano what's hooked up to where on the H bridge, we need to tell it whether the digital pins are being used as inputs or outputs. In this case they're all outputs.

In the Setup section you have all the `pinMode` commands to set the pins to input or output and the `attach` command for the servo.

Take note: The 2-word commands have a capital letter for the 2nd word. If you get it correct, the IDE (Sketch writing package) colours the command in red. Get it wrong and it stays black. Similarly with the INPUT, OUTPUT, HIGH, LOW values, they must be in capitals. If it's correct the IDE turns them blue. The servo is hardwired to the 5V but the control wire is hooked up to digital pin 9 on the Nano so we attach it to pin 9 then write to it the position we want to start in. In the case of this particular servo it can be anywhere between 0 and 180 degrees so let's set it to the middle with a `myservo.write(90)`.

All the setup work is done so now we move on to the Loop section.

The L293D H bridge has 2 channels. Motor A on one side and motor B on the other. In the case of motor A you have to set Input 1 HIGH and Input 2 LOW to make it run forwards but you must also set the Enable 1,2 HIGH or give it a PWM signal. Even though we're not changing the speed in this sketch we may as well use a PWM signal so we have the ability to change speeds later. To enable motor A with a PWM you do `analogWrite` to SpeedA (digital pin 5) and give it a value from 0 to 255. Zero being stopped and 255 full speed. Reverse the motor by swapping HIGH/LOW so Input1 is LOW and 2 is HIGH. Continue on with a delay after each change. `delay(2000)` is 2 seconds. Finally make the servo wave by writing 0 then 180 then 0 etc.

Once you've got this all working you can fiddle with the sketch. Change the motor speed, try different angles on the servo etc. Getting started is always the hardest part so I hope I've given you enough to get you on your way. I'm just a beginner too. I've learnt most of this watching YouTube tutorials.

Watch it on YouTube



<https://youtu.be/9zhToon4hOM>

In my video I've used a 7.4V LiPo battery that has a 2.1mm DC jack piggy-backed off the Deans connector but you can use any DC voltage from 7-12V.

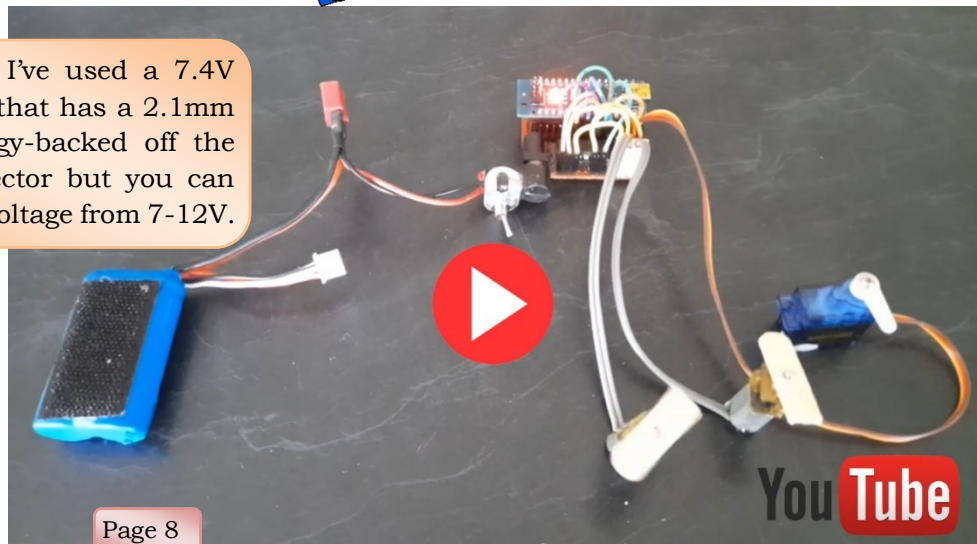

THE MAGIC ROUNDABOUT

Stan Knight Idaho



Having nothing else to do, I tried to find a use for an abundance of Pawls without Boss (p/n 147c)! It occurred to me that they could sort of represent the legs of a horse! So, I ended up with this mini-miniature roundabout. Perhaps a contender for the 'World's Smallest Meccano Roundabout'?

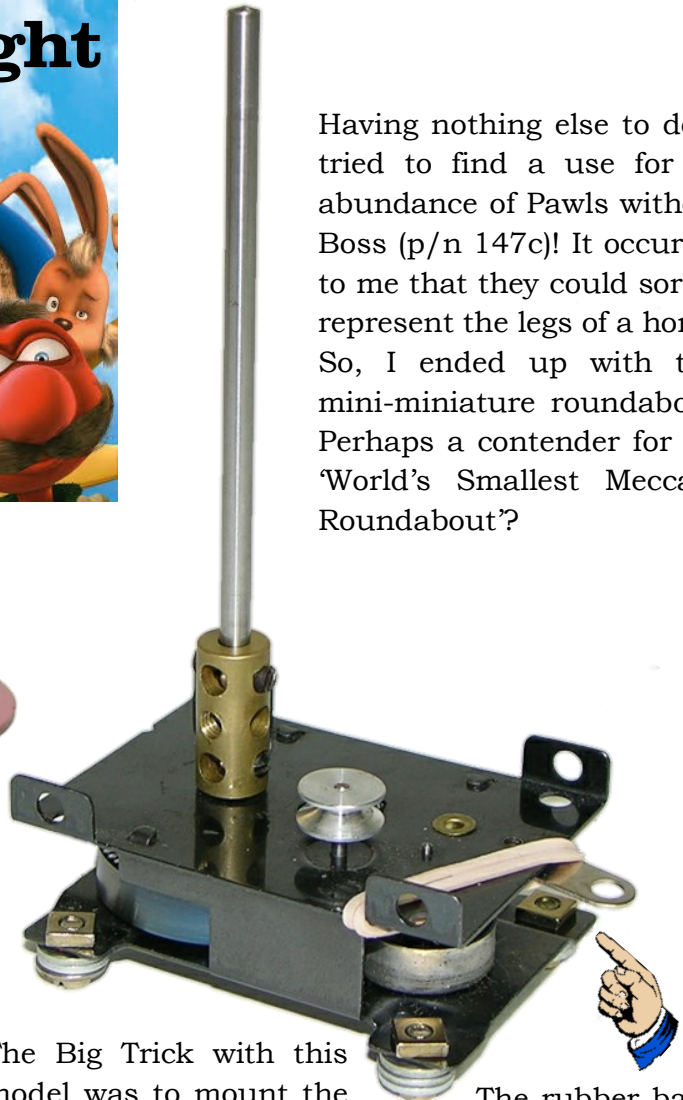

The Big Trick with this model was to mount the whole thing on the winding spindle of the Magic Motor. Two Grub Screws hold the Coupling in place on the spindle to help keep the Axle Rod vertical.

The rubber band is there because the brake on this Magic Motor will not hold on its own anymore!



A simple base – a 3½ inch Hub Disc (a 3½ inch Gear Wheel or 3-inch Pulley could replace that non-standard part), a Face Plate, a Sleeve Piece, and a couple of Chimney Adaptors for a centre column.

Before the Sleeve Piece is dropped in place, the Face Plate is fastened to the Rod.



The body of each horse is a Strip Coupling. The neck is 'trapped' in the slot of the Coupling. A short length of Meccano Cord is frayed to represent the tail.

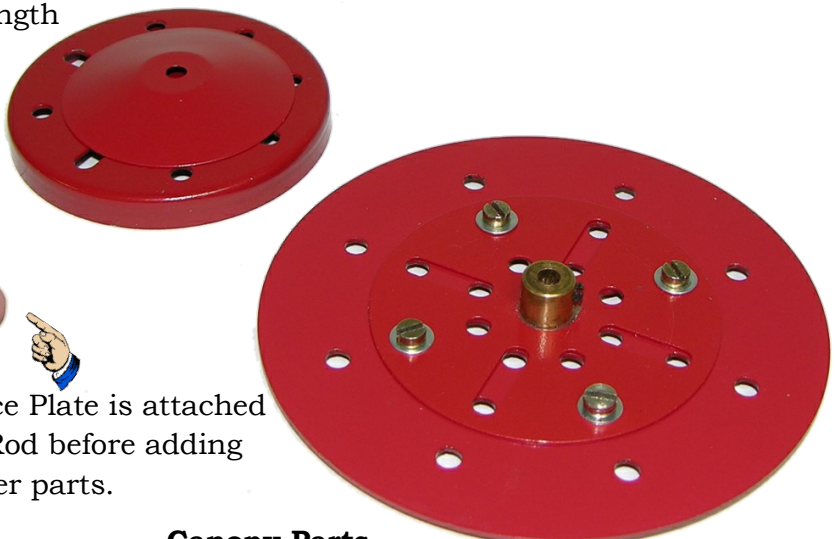

The Face Plate is attached to the Rod before adding the other parts.

Canopy Parts.

A 4-inch Circular Plate, a (non-standard) 2½ inch Wheel Flange (a normal one would do), and a Conical Disc.

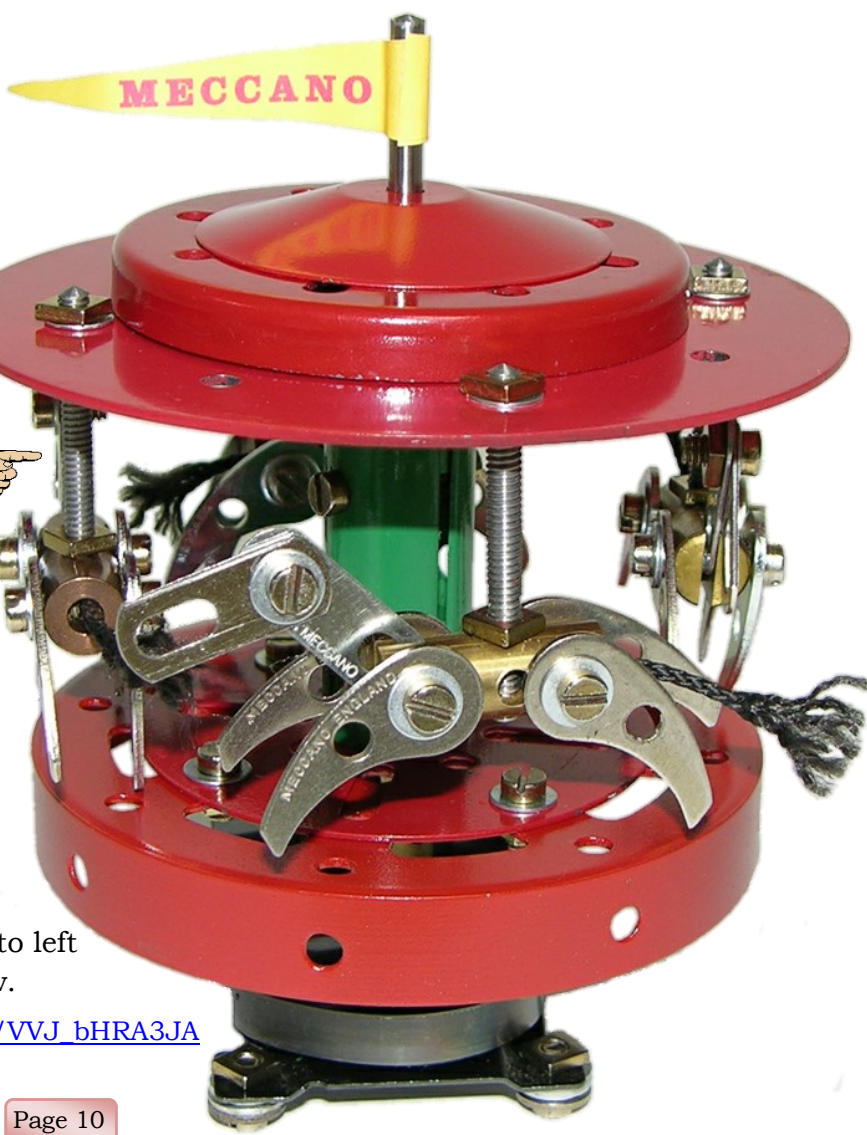
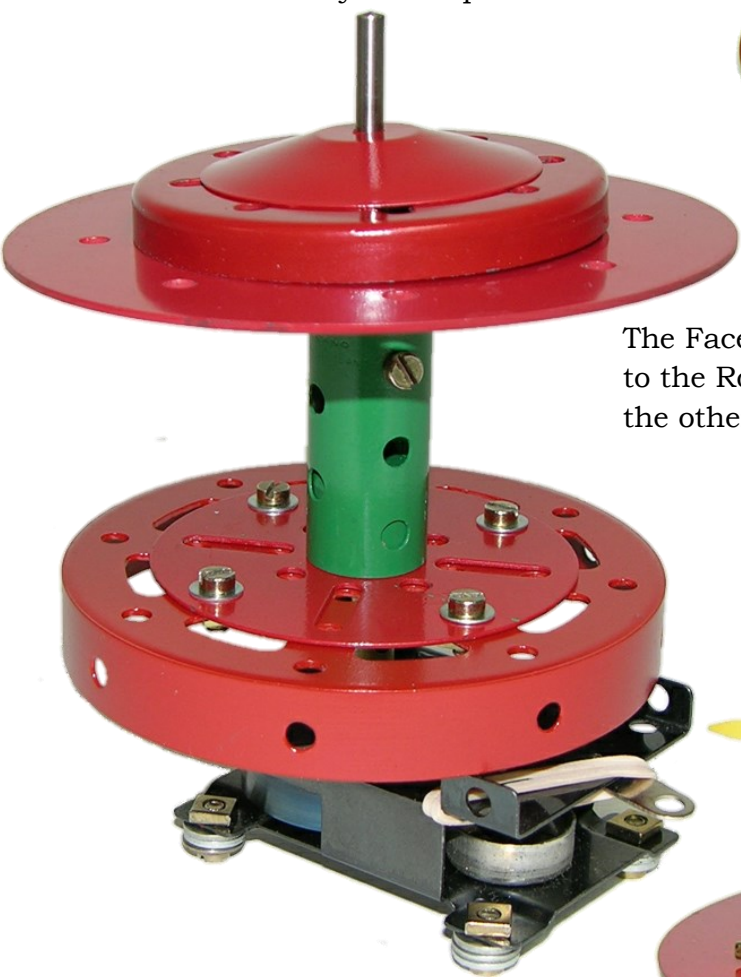

The horses are attached with short Screwed Rods. To wind up the Roundabout, the motor is held, and the base of the model turned anti-clockwise. Note that the Roundabout turns in the British direction!



Watch the video on YouTube by clicking the photo left or the link below.

https://youtu.be/VVJ_bHRA3JA



FROM OUR GOOD IDEAS DEPARTMENT

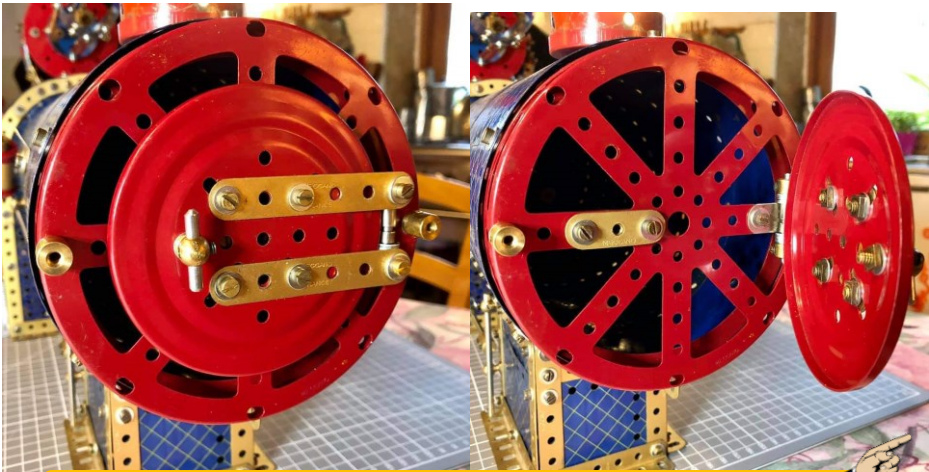

Peter Sullivan in Switzerland came up with this great idea to hold the firebox door closed. A nut is held captive behind a 3-hole Strip.

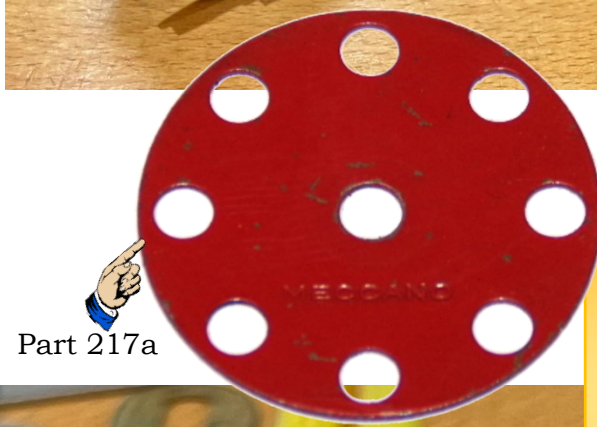
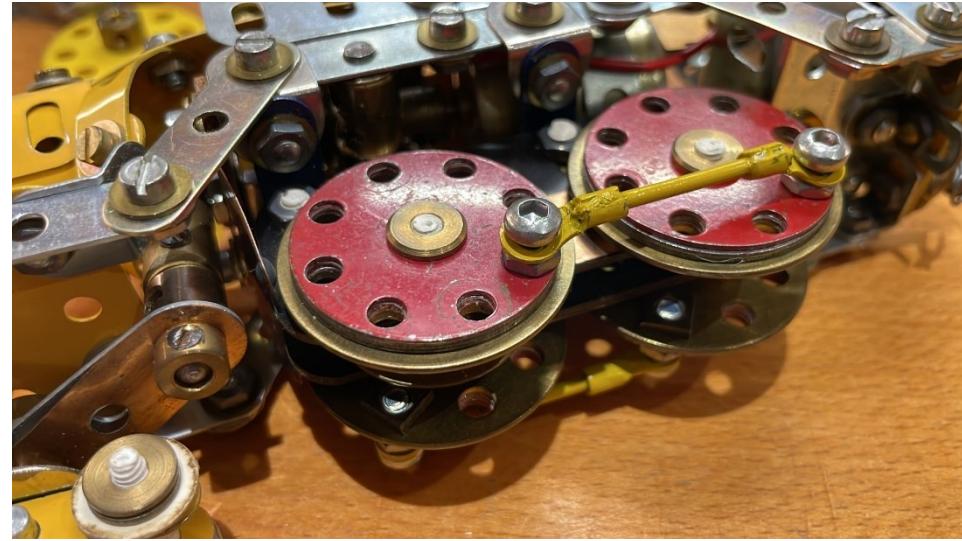

Part 217a

From Tim Gant is this neat idea to make an insulated train wheel using a 24a Wheel Disc as the flange with the smaller 217a Wheel Discs as the 'tread'. An Elektron 6ba Bolt and an Elektron Insulating Bush acts as the axle and keeps the wheels insulated from each other. The 50t gear is pre-1912 to ensure the wheels are close enough together to run on 00-gauge track. This lone axle was built purely to illustrate that it was possible to create a driven axle of a Hornby type train (taking its power from the rails) without butchering parts. My first version in that working engine used Army Multikit shells which I had threaded 5/32 BSW at each end. The drive was via a pulley (ca. 1910) which I found was a tight fit on some of the shells; however, over time the drive band perished, and it would be a pain to replace.

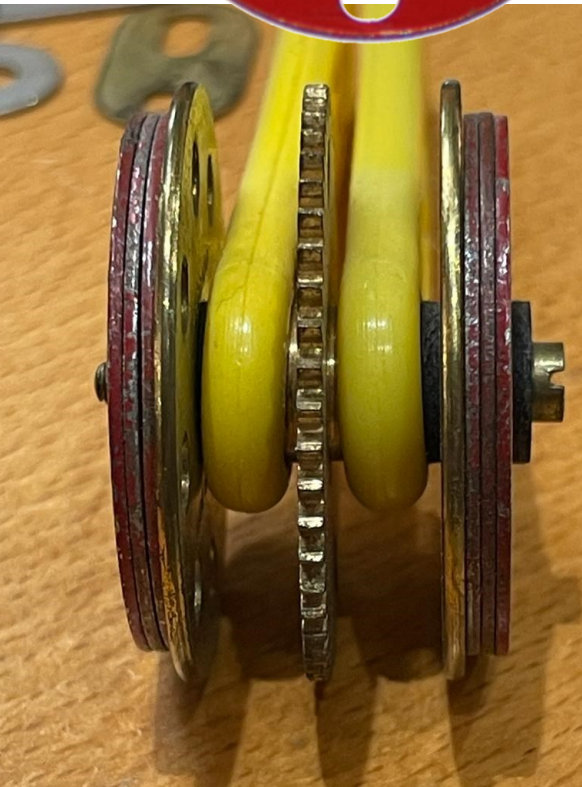

Melbourne Meccano Club Feb 2022



Jack Parsisson

Graham Jost

The MMCI February meeting at Jack Parsisson's house is always my favourite. It was great to see Jack's grey Fergie in the flesh. My day started at 6am and after driving for 2 hours to pick up Paul Dale from the airport, it took another 2 hours to get to Frankston. Graham Jost brought along a Gas Engine that failed miserably due to an electrical failure. (Oh, the irony!) Jim Munro had a Sea Plane and Anthony Burkitt was looking resplendent in his Meccano T shirt. Barry McDonald had his version of the Killen-Strait No. 3 Tractor and Ernie Morf showed his work in progress which is a caboose for his Shay Loco. Tony Ercolano had a massive struggle getting his Elvis firefighting helicopter from his car to the table but wow! What a massive model.



Jim Munro



Paul Dale - real gold



Anthony Burkitt



Ernie Morf



Barry McDonald

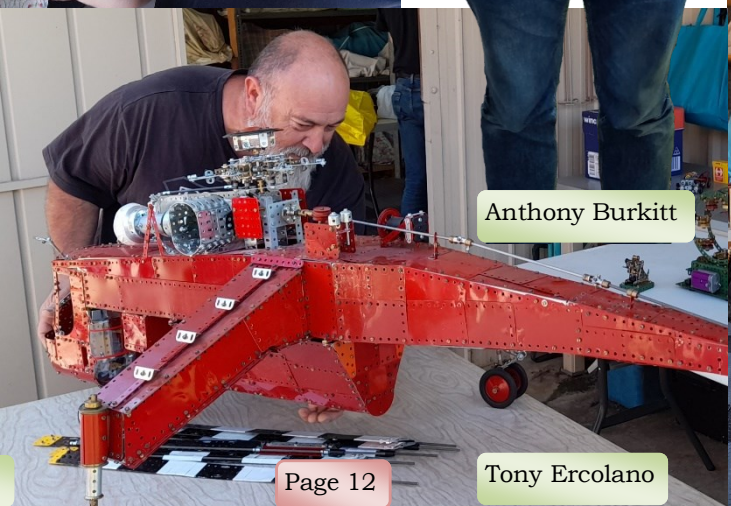

Tony Ercolano

This Month's Meccanogirl

When and where were you born?

A lady never reveals her age, but I was born Elfwyn Mary Crossley in the small Victorian country town of Natimuk, about 300 km from Melbourne.

Did you have Meccano as a child?

Oh yes. In fact, I had an Ezy-Bilt set before Graham!

Where did you go to school?

Natimuk Primary School followed by Horsham High School. I then gained a Bachelor of Agricultural Science degree at the University of Melbourne. This included one year at Dookie Agricultural College in northern Victoria.

What did you do for a living?

I worked as a water bacteriologist at the Melbourne Board of Works. But then along came marriage and soon I was home with the first of our children.

Mary Jost Australia



Mary at home aged 9.



Mary at work titrating water for the cameraman, 1960.

So, you married and had kids?

Yes, I knew Graham from my childhood and we both ended up at the same university and it progressed from there. We married in 1959 in Natimuk and had four children: Peter, Helen, Susan and Alison. We bought our first house in East Bentleigh in Melbourne in 1960 and we still live there today.

Did Meccano remain a part of your life?

No, not at all. But the interest remained in the family. While I was still in hospital with Peter, Graham came in with a sheepish look on his face one evening: he had just bought a No 9 Meccano set from a colleague at work, ostensibly for Peter one day!



Mary and Graham on their wedding day in a brand-new FC Holden.

From little things big things grow. Graham and Mary with all the family in 2015. L-R Frank, Lucie, Peter, Tim, Liam, Peter Jost, Helen Jost, Robyn, Susan Jost, Colin, Ruby, Phoebe (front), Maddy, Jasper, Alison Jost



Have you travelled much?

Early on in his career, Graham was awarded a PhD Research Scholarship. This was taken up at Southampton University, and we lived in England for three fabulous years in the late 1960s. With three small children to look after at this time, the opportunity to enjoy campervan holidays in the UK and Europe provided welcome breaks. Once Graham retired, we travelled overseas quite a lot to the UK, Europe and New Zealand. A memorable visit to Egypt was followed by visits to family in Canada, Japan and the Philippines.



Mary and Graham at King Tut's tomb in Egypt.

What about travelling to Meccano expos?

We've done plenty of that in Australia, New Zealand and the UK. We even managed to attend one CAM Expo in 2011. We visited SkegEx first in 1997, and several times since. We have also visited gatherings at TIMS, WLMS, Kew Bridge, MMG, NMMS and Henley in the UK and Meccano Conventions in Auckland, Palmerston Nth, Wellington, Nelson and Christchurch in New Zealand. A visit to the annual Sydney MMA show is also a regular. We've also stayed with kind Meccano folk on numerous occasions overseas, adding immeasurably to the enjoyment of those visits for us. Happily, we've been able to return the compliment here too. Dave and Sandy Feinstein from South Africa were our first overseas Meccano home visitors in 2001. We then all travelled on to our first biennial Meccano Convention at Upper Hutt in New Zealand.



Mary with Kees Trommel at SkegEx in 2008.



Mary with her butterflies at TePapa Expo in 2015. Photo: Gary Higgins.

Are you a member of any Meccano Clubs?

Yes, the Melbourne Meccano Club Inc, from its inception in 1984. It was a little while before I began modelling though, but I was quite pleased with my Meccano models, all of which have been of my own design. It began with, understandably, a Vase of Flowers (!) and finished with Earrings and a Tiara. I'm leaving any further Meccano modelling to Graham ...



What was your best model?

Probably my Noah's Ark – it was very popular with kids of all ages. As well as being shown here in Melbourne, it also travelled to Sydney and to Nelson, NZ. My Humpty Dumpty tableau was also very popular. There's a photo of Humpty in the Museum of Liverpool as part of a TV display highlighting how Meccano, as a local product, was exported around the world.

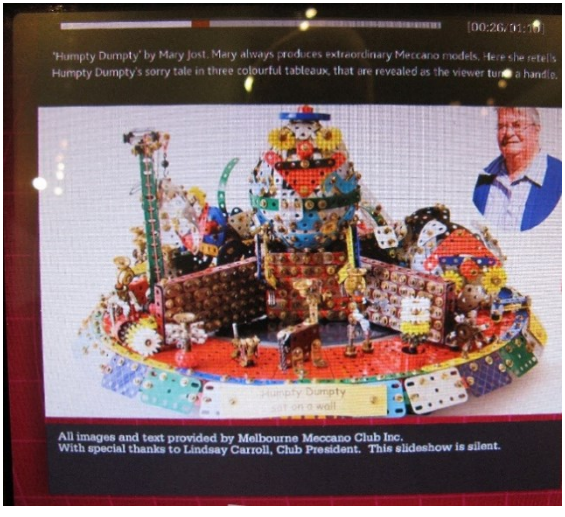

Liverpool Museum



The amazingly detailed Noah's Ark.

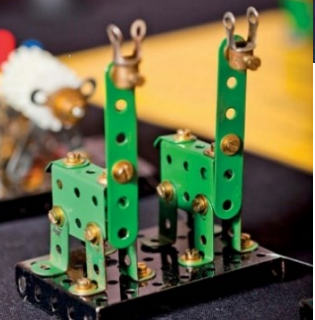

Humpty Dumpty's sad finale.



My favourite Christmas Tree.

What other interests do you have?
 Gardening has been a life-long interest which continues to this day. I have been involved with the Royal Botanic Gardens Melbourne for several decades and was a founding member of the Plant Craft Cottage Group there in 1981. That is a wonderful resource for promoting all aspects of crafts relating to plants. My particular interests have been natural dyeing and basketry, and the family and the PCC Shop have been the beneficiaries! I was also a Guide Leader for many years while my daughters were of Guiding age. We all enjoyed that, and one achieved her BP Award.

What's your advice for girls growing up in a male dominated world?
 Well thankfully that's changing but whatever advice I might be able to offer girls, or boys, today, would be at least one generation out of touch, and ignored. Just get on with it and do it your way.

See more of Mary's models in the NZM gallery and YouTube links below.

<https://www.nzmeccano.com/image-101894>

<https://youtu.be/mOrHtpqM9lo>



Bling!

We are John & Johnny. A father and son team who like Meccano. We're nothing to do with Spin Master who own the brand. Contact us at

MeccanoNews@gmail.com

Follow Johnny Meccano on 



UK

- <https://tims.org.uk>
- <https://nelmc.org.uk>
- <https://nmmg.org.uk>
- <https://www.selmec.org.uk>
- <https://southwestmeccano.org.uk>
- <https://londonmeccanoclub.org.uk>
- <http://www.hsomerville.com/wlms>
- <http://www.northwestmeccano.co.uk>
- <https://northeasternmeccano.org.uk>
- <https://www.meccanoscotland.org.uk>
- <http://www.corlustmeccanoclub.co.uk>
- <https://runnymedemeccanoguild.org.uk>
- <http://www.midlandsmeccanoguild.com>

Other Countries

- <http://club-amis-meccano.net/>
- <http://www.meccaninfos.com.ar/>
- <http://www.meccanogilde.nl>
- <http://meccano.free-bb.fr/>
- <https://www.aceam.org/es/>
- <https://www.metallbaukasten-forum.de/>
- <http://www.amsclub.ch/>
- <http://www.meccanoweb.es/>
- <http://www.la-roue-tourne.fr/index.php/le-meccano/notices-et-plans>

USA and Canada

- https://www.spinmaster.com/brand.php?brand=cat_meccano
- <https://www.usmeccano.com>
- <http://www.meccano.com>
- <http://www.cmamas.ca>
- <http://www.bcmeccanomodellers.com/meccano-in-canada.html>
- <http://www.meccanoquebec.org/index2ang.html>
- <http://www.melright.com/meccanosales/>



New Zealand

- <http://www.nzmeccano.com>
- <http://www.nzfnm.co.nz>
- <https://www.facebook.com/MWT-Meccano-Club-1476153515979522/>

Australia

- <http://www.mmci.com.au>
- <http://www.sydneymeccanomodellers.org.au>
- <http://www.webjournalist.com.au/maylands/index.html>

South Africa

- <https://www.facebook.com/Meccano-Club-of-South-Africa-464753870326296>
- <http://www.mecworld.co.za/cmpr/>

Personal pages

- <https://www.alansmeccano.org>
- <http://www.users.zetnet.co.uk/dms/meccano>
- <http://www.dalefield.com/meccano/index.html>
- <http://www.meccano.us>
- <https://www.meccanoindex.co.uk>
- <http://www.meccanokinematics.net>
- <https://neilsmeccanoandstuff.jimdofree.com/neil-s-meccano-models>

Meccano suppliers

- <http://www.meccanohobby.co.uk>
- <https://www.meccanoshop.co.uk>
- <http://meccanoman.co.uk/catalog>
- <https://www.meccanospare.com>
- <https://ralphsshop.com>
- <http://www.hsomerville.com/mwmailorder>
- <http://www.metalconstructiontoys.com>
- <http://www.meerlu.com.au/>
- <https://tinyurl.com/AshokBanerjee>

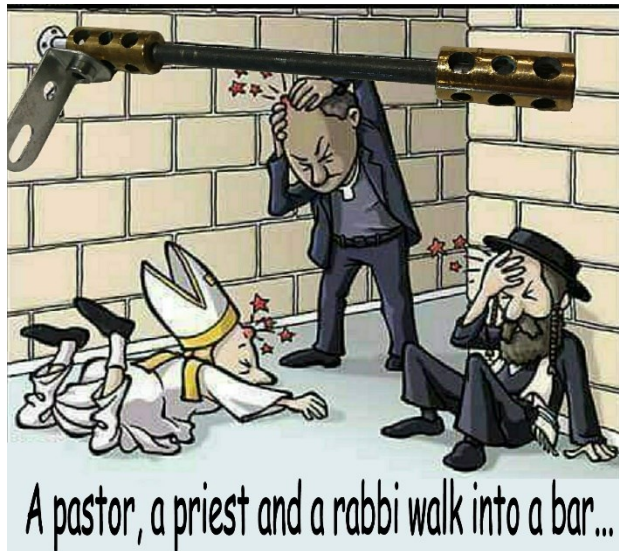

A pastor, a priest and a rabbi walk into a bar...

An engineer was crossing a road one day when a frog called out to him. "If you kiss me, I'll turn into a beautiful princess," said the frog. He bent over, picked up the frog and put it in his pocket. The frog then cried out, "If you kiss me and turn me back into a princess, I'll stay with you for one week and do ANYTHING you want." Again, the engineer took the frog out, smiled at it and put it back into his pocket. "What is the matter?" the frog asked. "I've told you I'm a beautiful princess and that I'll stay with you for one week and do anything you want. Why won't you kiss me?" "Look," said the man. "I'm an engineer. I don't have time for a girlfriend, but a talking frog - now that's cool!"

3 women die together in an accident and go to heaven. When they get there, St. Peter says, 'We only have one rule here in heaven: Don't step on the ducks!' So, they enter heaven, and sure enough, there are ducks all over the place. It is almost impossible not to step on a duck, and although they try their best to avoid them, the 1st woman accidentally steps on one. Along comes St. Peter with the ugliest man she ever saw. St. Peter chains them together and says, 'Your punishment for stepping on a duck is to spend eternity chained to this ugly man!' The next day, the 2nd woman steps accidentally on a duck and along comes St. Peter, who doesn't miss a thing, with him is another extremely ugly man, He chains them together with the same admonishment as for the 1st woman. The 3rd woman has observed all this, and not wanting to be chained for all eternity to an ugly man, is VERY, VERY careful where she steps. She manages to go months without stepping on any ducks, then one day St. Peter comes up to her with the most handsome man she has ever laid eyes on Tall, Muscular, and Young. St. Peter chains them together without saying a word. The happy woman says, 'I wonder what I did to deserve being chained to you for all of eternity?' The guy says, 'I don't know about you, but I stepped on a duck!'

Experience is the hardest kind of teacher. It gives you the test first, and the lesson afterward.

When one door closes another one opens. Other than that, it's a pretty good car.

There are 10 types of people in this world: those who understand binary, and those who don't.

If you don't look back on your younger self and think, "I was so stupid then!", you're probably still stupid.

Meccgear Jeff Clark New Zealand sales@meccgear.co.nz No website yet but a pricelist with photos can be downloaded here <http://www.nzmeccano.com/image-151916> Bespoke parts from Corlust Meccano Club Ian Wilson bespokecraftshack@gmail.com Mike Rhoades.Link to price list below <https://www.nzmeccano.com/image-165106>