

Earth, Moon, Sun Orrery

Peter Harwood - UK

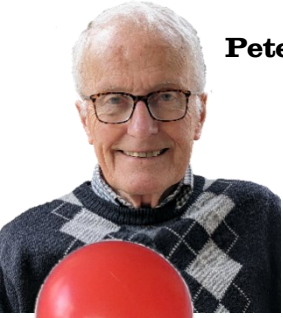

The Earth, tilted at 23.5°, rotates in a Meccano day of 0.5 seconds while the Moon, with its orbit tilted at 5°, moves round the Earth in 15 seconds, a Meccano month of 30 Meccano days. The horizontal arm rotates round the Sun on the left in about 3 minutes, a Meccano year of 361 Meccano days. The platform supporting the Earth and Moon counter-rotates to maintain the Earth's axis and the Moon's orbit in a fixed direction as they move round the Sun. A 3½" Circular Girder is used to provide the

floating bearing for the Moon. At this scale the Sun should really be the size of a standard Meccano hole and the Earth and Moon would be invisibly small. To make a meaningful working model, the Earth and Moon are reproduced to scale but are actually far too close together, while the Sun is 100 times smaller in diameter than it should be.

Chris Shute's novel entry for the 2022 Spanner II Internet Christmas Challenge (Build a model from a 1978 Set 5) was the inspiration for this model. Free of the Set 5 constraint, the motions of the Earth and Moon are represented in detail.

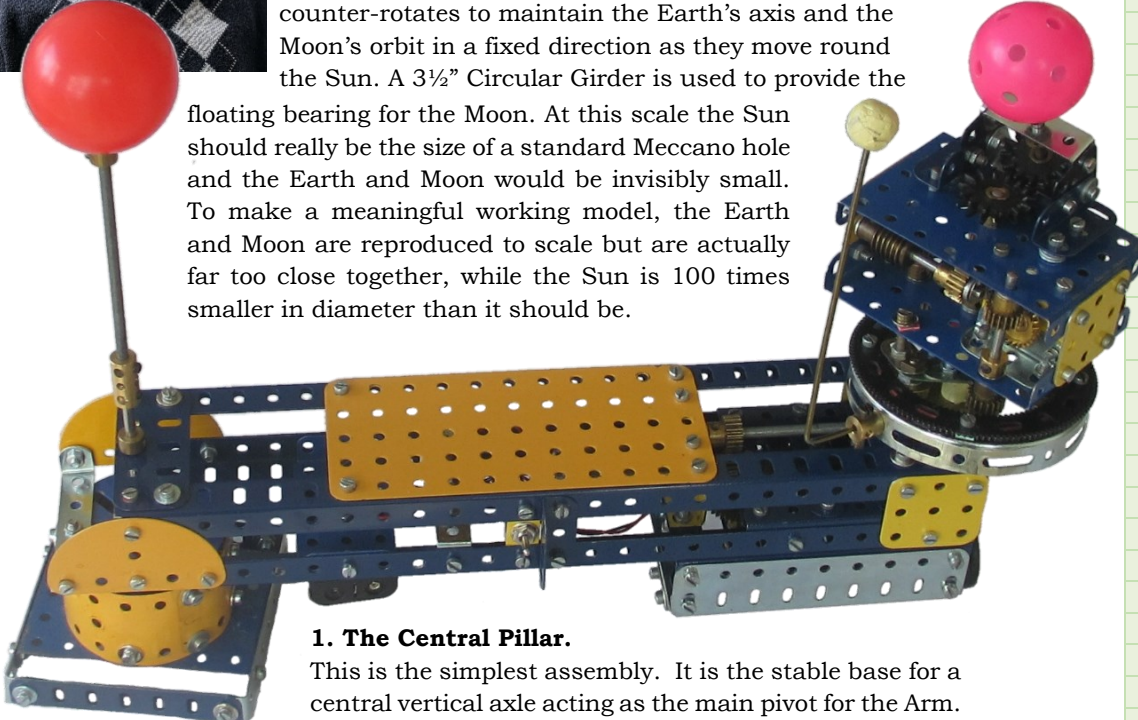

1. The Central Pillar.

This is the simplest assembly. It is the stable base for a central vertical axle acting as the main pivot for the Arm.

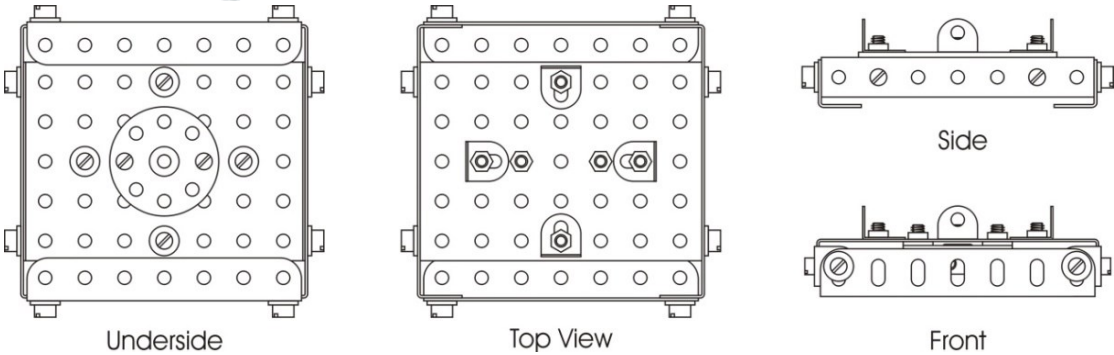

Fit a Bush Wheel to the underside of a 2½" x 3½" Flanged Plate separated by Washers. With two Washers under the head of each Bolt, fit four Angle Brackets set in as far as the slots will allow. Fit two 3½" Double Angle Strips (DAS) and Angle Girders as low as the slotted holes will allow. This is the correct height for supporting the Arm. Rubber feet may be fitted under the Girders, with the height adjusted accordingly.

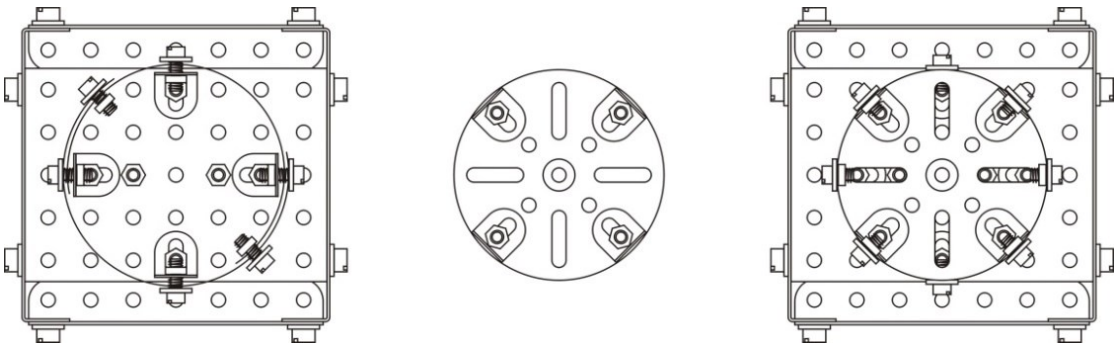

Bend up two 1½" x 5½" Flexible Plates and fit them round the Angle Brackets. The additional Bolts at the ends of the Flexible Plates are in the lower holes. The Bolts are shown untightened and need coaxing into place to neatly close the cylinder. Fit four Angle Brackets on the boss side of a Faceplate with the hole faces in line with the rim. Remove the set screw from the boss and fit this assembly in the top of the cylinder. Fit a 4" axle through the Faceplate boss and just through the Bush Wheel boss and tighten the set screw to hold it in place.

Part No.	Description	Qty
5	Strip 2½"	10
6a	Strip 1½"	4
8	Angle girder 12½"	4
9a	Angle girder 4½"	4
9b	Angle girder 3½"	2
9d	Angle girder 2½"	3
9f	Angle girder 1½"	7
10	Fishplate	2
12	Angle bracket	9
13a	Axle Rod 8"	1
14a	Axle Rod 5½"	1
15	Axle Rod 5"	1
15b	Axle Rod 4"	2
16	Axle Rod 3½"	1
16a	Axle Rod 2½"	3
17	Axle Rod 2"	3
18a	Axle Rod 1½"	2
22	Pulley 1"	1
23	Pulley ½" no boss	3
24	Bush wheel	2
25	Pinion 25t	2
26	Pinion 19t	10
27	Gear 50t	2
27a	Gear 57t	3
27f	Gear Multi-purpose	2
29	Contrate ¾"	2
30	Bevel 26t	4
31	Gear 1" 38t	2
32	Worm	2
37b	Bolt	127
37c	Hex Nut	160
38	Washer	143
48	Double angle strip 1½" x ½"	2
48a	Double angle strip 2½" x ½"	4
48b	Double angle strip 3½" x ½"	2
51	Flanged plate 2½" x 1½"	1
51b	Flanged plate 1½" x 1½"	1
53	Flanged plate 3½" x 2½"	3
55a	Slotted strip 2½"	3
59	Collar	12
63	Coupling	2
64	Threaded boss	1
69c	Grub screw short	3
70	Flat plate 5½" x 2½"	1
74	Flat plate 1½" x 1½"	5
103c	Flat girder 4½"	2
103f	Flat girder 2½"	2
103l	Flat girder 1"	2
109	Face plate 2½"	2
111	Bolt ¾"	4
111c	Bolt ¾"	8
133a	Corner bracket 1"	1
143a	Circular Girder 3½"	1
147f	Pivot Bolt ¾"	3
155	Rubber Ring for 1" pulley	1
180	Gear Ring	1
189	Flexible plate 5½" x 1½"	2
214	Semi-circular plate	2

2. The Horizontal Arm.

Assemble the Arm in two layers commencing with the lower layer. As access is awkward the bulk of the Arm assembly should be built before the upper layer is added. Build these two sub-assemblies from 2½" Strips and 2½" and 4½" Angle Girders with the Bolts finger tight. Use ⅜" Bolts with three Washers where shown.

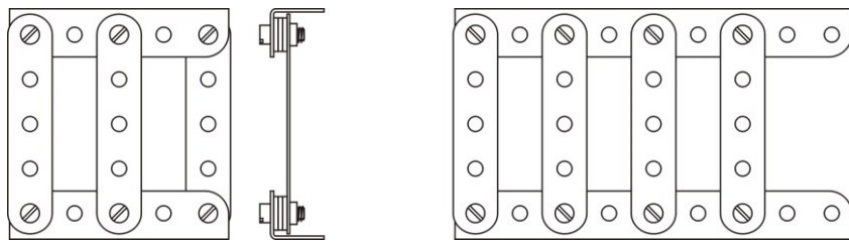

Now make a start on the Arm's lower layer by fitting a 1½" x 2½" Flanged Plate hard against the slotted faces of two 12½" Angle Girders and separated by Washers from the Girders. To the right, fit the Faceplate, Semi-circular Plates and DAS with a standard and thin Washer on each side between the DAS and the Plates. Fit a second DAS to the left of the Flanged Plate with Washers inserted on each side. A Fishplate is a useful thin washer.

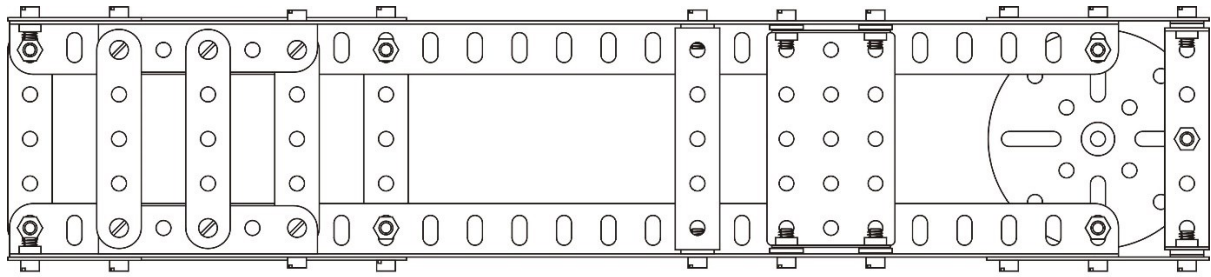

Top View

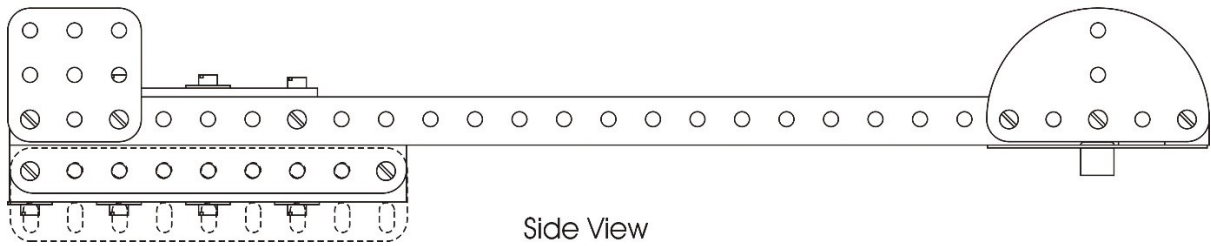

Side View

Fit the first sub-assembly between the 12½" Angle Girders with the edges of the 2½" Angle Girders firmly against the 12½" Angle Girders, and with 1½" square Plates on each side. Bolt 4½" Angle Girders on each side under the 12½" Angle Girders, with a 2½" Strip under the Bolt heads at the right-hand end. (Note that the left-hand 2½" Strip in the top view is part of the second sub-assembly). Insert the second sub-assembly between the 4½" Angle Girders and bolt it in place with 4½" Flat Girders on the outside (shown by the broken lines). The seven Strips mounted on the hole faces of the 2½" and 4½" Angle Girders will act as bearings for meshing gears. To ensure that they are at the correct separation, set each Strip as far to the left as the play in the Bolts will allow before tightening the Bolts. This will also provide additional clearance for some Bevel Gears.

The manufacturing tolerance on Meccano parts with a bend is very variable, particularly Angle Girders. These instructions assume that they are to specification, but the Washers needed could vary. The key is that the width of the Arm is determined by the 2½" bearing Strips and supporting Angle Girders.

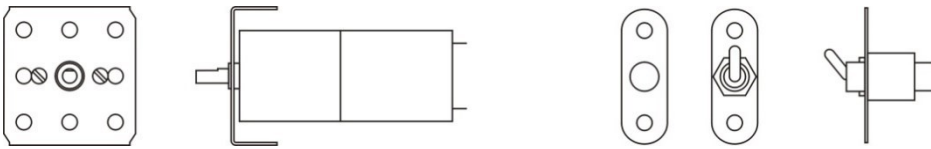

The model requires a 120rpm 3V geared motor, an On/Off switch and a battery box containing two AA batteries. A 250rpm 6V motor would serve, running at 3V.

One convenient way to mount the motor is to use a modified 1.5" square Flanged Plate, and this is the method adopted here. Separate the motor and the Plate with Washers to give clearance, as the hole in the plate directly above the motor shaft is used as a bearing. Also, the motor boss must not protrude from the front face of the Plate. Mount a suitable switch on a modified 1½" Strip.

Fit the motor mounting Plate to the right-hand 2½" Strip in the Arm lower layer with Washers between the mounting Plate and Strip. Fit the switch with a protective 1½" Angle Girder alongside. Mount the battery box underneath the 1½" x 2½" Flanged Plate. Fit a terminal block under the DAS next to the Flanged Plate and make the connections so that the motor runs clockwise.

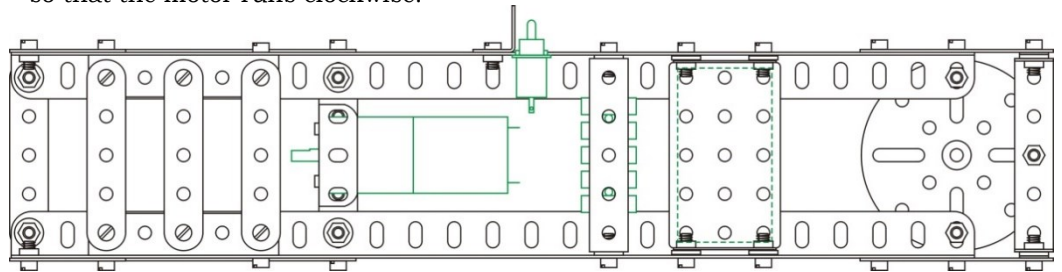

Commence building the Arm upper layer from two 12½" Angle Girders, a 2½" x 5½" Plate and a 2½" Flat Girder. Make up the composite 2½" Strips shown to the left and fit them on top with the ⅜" Bolts pointing upwards. Add a 2½" Angle Girder with the hole flange to the left. Bolt the Arm upper layer in place on the lower layer. Add Washers if needed where the motor support Flanged Plate sits against the inside face of the 2½" x 5½" Plate.

Set the composite 2½" Strips as far to the left and the 2½" Angle Girder as far to the right as the play in the Bolts will allow. Adjust the composite strip so that an axle will run freely in the centre holes of it and the lower bearing strip, with the axle vertical. Insert an axle through the centre hole of the 2½" Flat Girder and the Faceplate boss and adjust for free running.

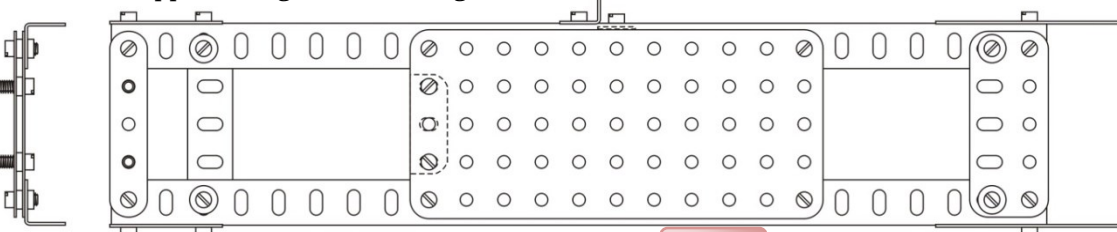

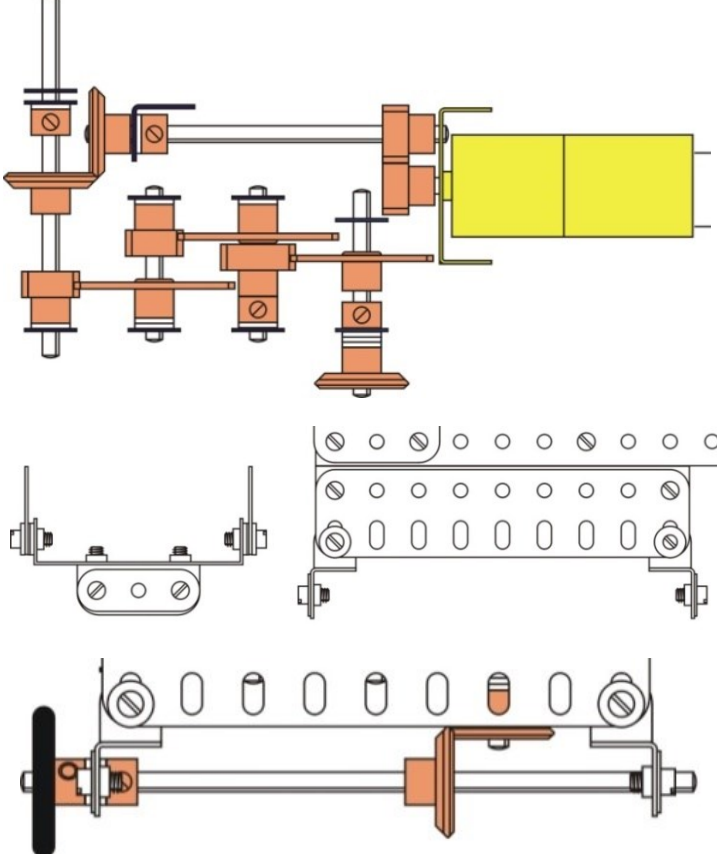

This is a cross-section of the Arm gearing with the structure restricted to the bearing Strips, the top 2½" Angle Girder and the motor assembly. It is easiest to fit the gearing in the following order:

- Motor 19t Pinion.
- Vertical 2" axle with Bevel, Collar and 50t Gear.
- Right 1½" axle with Collar, 25t Gear with short Grub Screw and 57t Gear.
- Left 1½" axle with 57t Gear and 19t Pinion.
- Horizontal 3½" axle with Bevel, Collar with short Grub Screw and 19t Pinion.
- Temporary vertical 3½" axle with Bevel, Collar and 19t Pinion.

Make up two sets of bearings from 2½" DAS, 1½" Angle Girders and 1½" Strips and fit them to each end of the 4½" Flat Girders with the Bolts at the lower ends of the slotted holes.

Fit a 5½" axle with a 1" Pulley with Rubber Ring, Collar and a Bevel Gear.
Mount the Arm on the Central Pillar with four Washers underneath and check that it rotates smoothly anticlockwise when under power.

3. The Platform.

The Platform is made up from two 2½" x 3½" Flanged Plates connected by 1½" square Plates. There is a lot going on at the top, inside and underneath, and access is quite awkward. The approach is to build the structure on the upper and lower Flanged Plates before they are put together for final assembly.

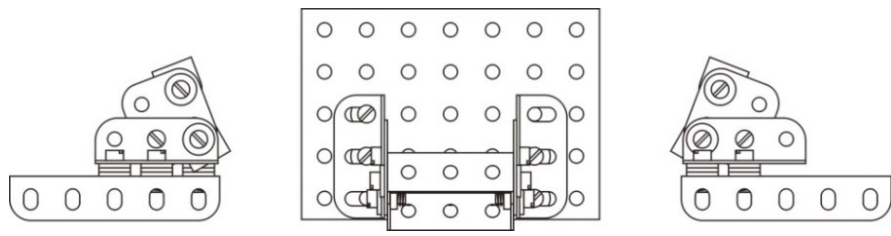

On the top Flanged Plate, build the supporting structure for the inclined Earth axle from two 1" Flat Girders, 1½" Angle Girder and 1½" DAS, using ⅜" Bolts to mount the Angle Girder. (No room for washers under the boltheads). The axle angle will be set up later.

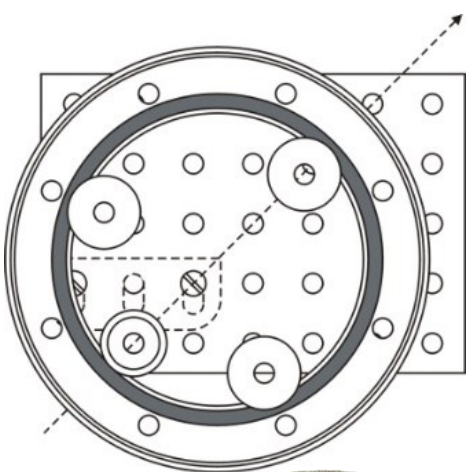

Build this sub-assembly on a 1½" square Plate using ¾" Bolts to support the 1½" Strip with four Washers and a Collar as spacers on each Bolt.

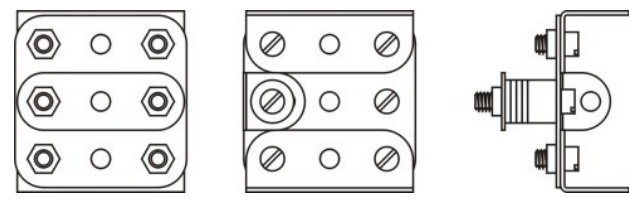

Mount the plate sub-assembly under the top Flanged Plate in the position shown by the broken lines and fit 1½" square Plates to each flange.

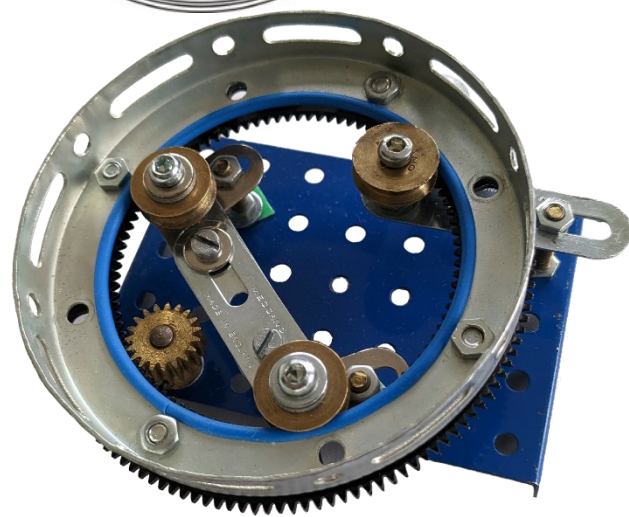
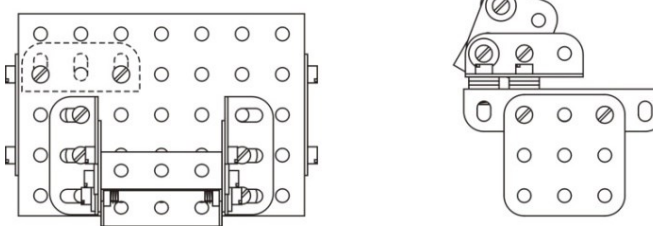

These images are of the underside of the Platform during assembly. The 3.5" Circular Girder rotates at angle of 5° to the platform surface. A Threaded Boss will be fitted to the side of the Circular Girder for an arm supporting the Moon. The Circular Girder is tilted along the diagonal line and is offset from the centre hole in the Flanged Plate by the right amount to get the Moon to orbit the Earth at a constant distance.

Orientation is shown by the broken lines indicating where the 1½" square Plate sub-assembly will fit. The Circular Girder runs on three free ½" Pulleys and is driven by a Gear Ring mounted to it which engages with a 19t Pinion.

Commence the lower Flanged Plate assembly by fitting two 3/4" Bolts inclined at approximately 5° along the plane of the diagonal line. These will support the first two Pulleys and require 0.5mm spacers cut with scissors from a plastic container. Fit opposing spacers under the two Washers on each Bolt. The third Pulley, to be mounted on the third and fourth 3/4" Bolts, will sit across the 45° line, and does not need to be inclined. Mount the third Bolt on a 1" Corner Bracket which is pushed in as far as the fixings will allow, then the fourth Bolt.

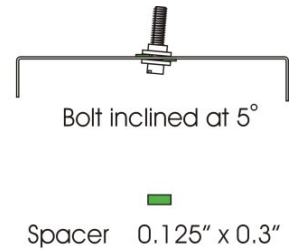
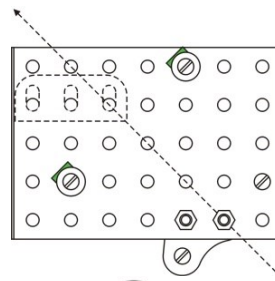

Fit the upper and lower Flanged Plate assemblies together with bolts at each end of the 1 1/2" Angle Girders and in each corner of the outer 1 1/2" square Plates.

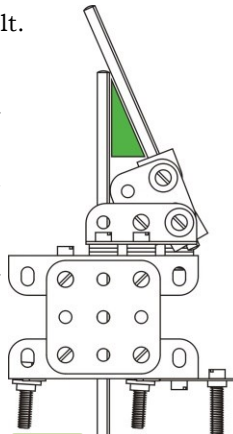

Fig 1

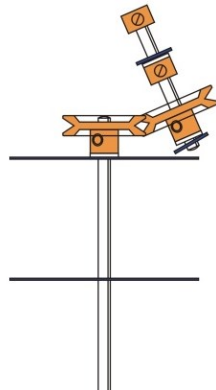

Fig 2

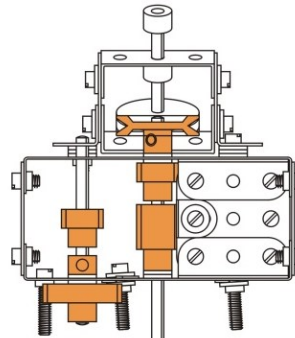

Fig 3

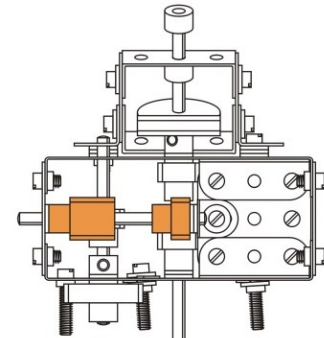

Fig 4

Fig 1. To set the Earth's axis to 23.5°, insert a temporary 5" axle through the centre hole of the platform and a 3 1/2" axle in the 1 1/2" DAS centre holes. Make up a 23.5° template from card and adjust the 1 1/2" DAS to fit. The two 1 1/2" DAS need not be at right angles to the axle in this view so long as it can rotate freely.

Fig 2. Fit the axles with two Multipurpose Gears. They should engage correctly. If not, adjust the 3 1/2" axle position to obtain the correct engagement while maintaining the 23.5° setting. Then replace the 3 1/2" axle with a 2" one and add the retaining Collar and a Collar flush with the top.

Fig 3. Replace the 5" axle with the final, perfectly straight, 8" axle. This is the drive axle for the Earth's rotation via the Multipurpose Gears, the counter-rotation of the platform, and the Moon's orbit. On this axle, fit a Worm Gear driving the counter-rotation and a 19t Pinion driving the Moon's orbit and the top Multipurpose Gear, with the axle just through its boss. On a 2 1/2" axle one inch to the left, install a 19t Pinion, Collar and 1" 38t Gear.

Fig 4. Add a horizontal 2.5" axle plus a 19t Pinion and a Worm. Added clearance is available if needed by moving the outer 1 1/2" Plate forwards on its fixing Bolts. This completes the 361:1 counter-rotation gear train that defines the Meccano year. A second 38t Gear that is held stationary will engage with the one already fitted, to cause the Platform to rotate.

These are part of the gear train for the Moon's orbit. They provide a six to one reduction and reverse drive to a 19t Pinion that will engage with the 95t Gear Ring.

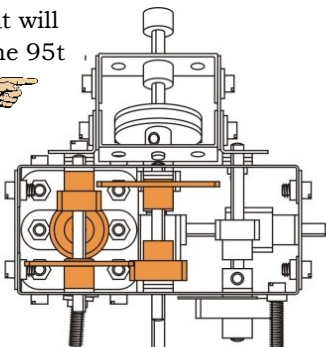

Fig 5

Fig 5. This is a cross-section of the internal 1 1/2" square Plate showing just the Plate and the 1 1/2" Strip. Fit a 1 1/2" axle with 3/4" Contrates at each end. The number of Washers may need adjustment to obtain the correct engagement.

Fig 6. Fit a 2" axle with a 57t Gear engaging with the 19t Pinion on the central axle and carrying a 25t Gear. Install a second 2" axle with a 50t Gear engaging with the 25t Gear and a 19t Pinion engaging with a 3/4" Contrate.

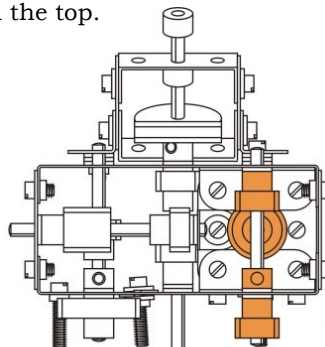

Fig 6

Fig 7. Fit a 2 1/2" axle with a 19t Pinion engaging with the second Contrate, plus a Collar and a 19t Pinion below the platform.

The Circular Girder assembly consists of the 3 1/2" Circular Girder and Gear Ring. This, with the 6:1 reduction to the output 19T Pinion, gives the 30:1 needed to define the Meccano month.

Fig 9. One Nut thickness is not quite enough to provide clearance. Make up four spacers from 0.5mm plastic as shown with the hole set in the same distance as a Nut.

Fig 10. Install Bolts with Nuts at four points on the Gear Ring before fitting it to the Circular Girder with the spacers inserted.

Fig 11. Make sure that the Nuts on both sides and the spacers are not interfering with the PVC lining.

Fig 8. To give clearance for the 1/2" Pulleys to run on the inside rim and to provide the ideal running surface, line the Gear Ring with PVC insulation just over 2mm in diameter. This is from standard 5-amp twin and earth lighting cable and about 8" is all that is needed. Split the insulation along the centreline to provide the perfect lining.

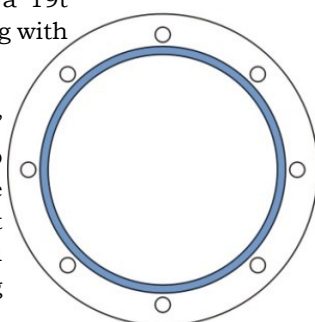

Fig 8

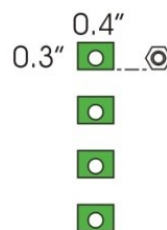

Fig 9

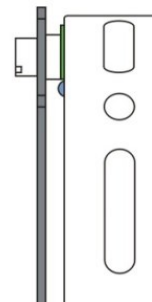

Fig 10

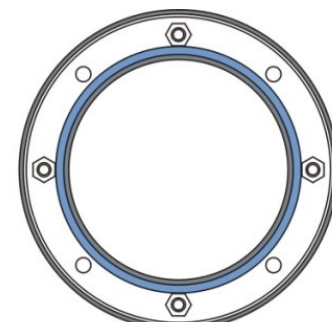

Fig 11

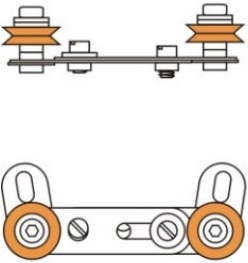

Fig 12

Fig 12. Build the first pulley support from two Slotted Strips with the lower Strip hard against a Fishplate to set the distance between the Pulleys. Hex head Pivot Bolts are used here, but Threaded Pins can be used instead, with just enough room on top of the pulleys for retaining collars.

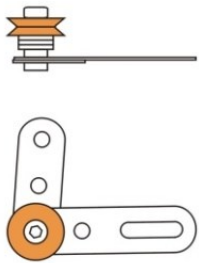

Fig 13

Fig 13. Build the second pulley support from a Slotted Strip and 1 1/2" Strip.



And everything under the Sun is in tune
 But the Sun is eclipsed by the Moon.
 - Eclipse, Dark Side of the Moon.
 Pink Floyd.

4. Final Assembly.

Remove the temporary vertical 3 1/2" axle from the Arm and, with a Washer under the support Bush Wheel, fit the Platform assembly, refitting the Bevel Gear and 19t Pinion. The support Bush Wheel will engage with the 3/8" Bolts to hold it stationary. Note that the weight of the platform assembly must be on the Washer under the Bush Wheel, not the one under the 19t Gear. Otherwise, the friction brake will not work.

Make the Moon Arm from a wire coat hanger and fit it in the Threaded Bush so that it is at right angles to the Circular Girder.

Use a Coupling to fit a 4" axle to the central pivot axle and mount a Collar flush with the top. The axle and Coupling are removable for stowage and transportation.

5. The Earth, Moon and Sun.

This is an easy way to represent the heavenly bodies. A plastic golf practice ball represents the Earth. To scale, the Moon should be just under 1/2" in diameter. This is made up from narrow strips of masking tape wound into a ball. The Sun is a light 2" plastic ball found in a toy cupboard. Fit the Earth and Sun to their supporting Collars with double sided sticky tape.

Make a hole in the Moon with a sharp point and fit it to the Moon Arm. The model is now complete.

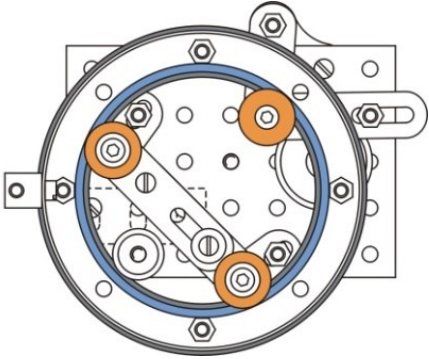

Fig 14

Fig 14. Install the first pulley support between Nuts on the 3/4" Bolts with two threads clear at the top. Install the Slotted Strip of the second support between Nuts at the top of the right 3/4" Bolt. Now fit the Circular Girder assembly. Fit the 1 1/2" Strip (also at the top of the Bolt between Nuts) and adjust for free running with the 19t Pinion engaged with the Gear Ring. There is very little clearance between boltheads on the Gear Ring and the Slotted Strip supporting the third Pulley. This can be increased, if necessary, by moving the Slotted Strip a thread or two down from the top of the 3/4" Bolt.

Fit a threaded bush on the outer flange of the ring girder to carry the Moon arm.

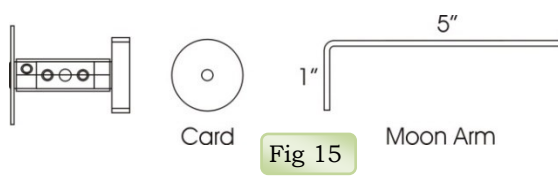
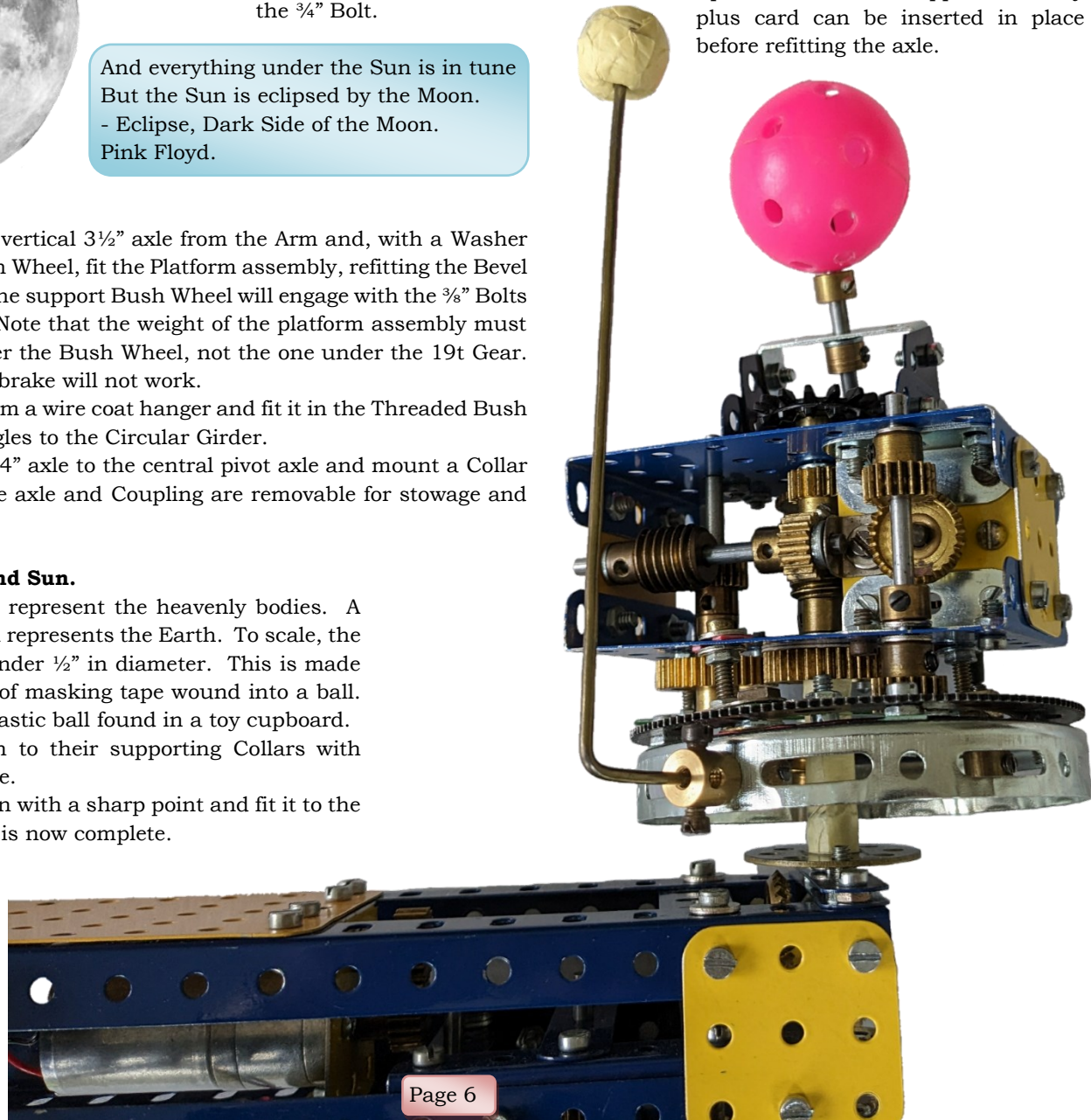

Fig 15

Fig 15. Wrap masking tape or other flexible sticky tape round the boss of a Bush Wheel, a Coupling and the boss of a 38t Gear to form the platform support, having removed all set screws. The 8" platform drive axle must rotate freely through this assembly and the three items need to be self-aligning. One layer of tape is sufficient.

There is a lot of backlash in the platform gearing. As the Platform rotates continuously in one direction, take up the backlash by fitting a disc of card above the 1" Gear to act as a friction brake.

To fit the support assembly, loosen the gearing on the 8" axle and slide it upwards so that the support assembly plus card can be inserted in place before refitting the axle.



F1 Car Plays Australian National Anthem

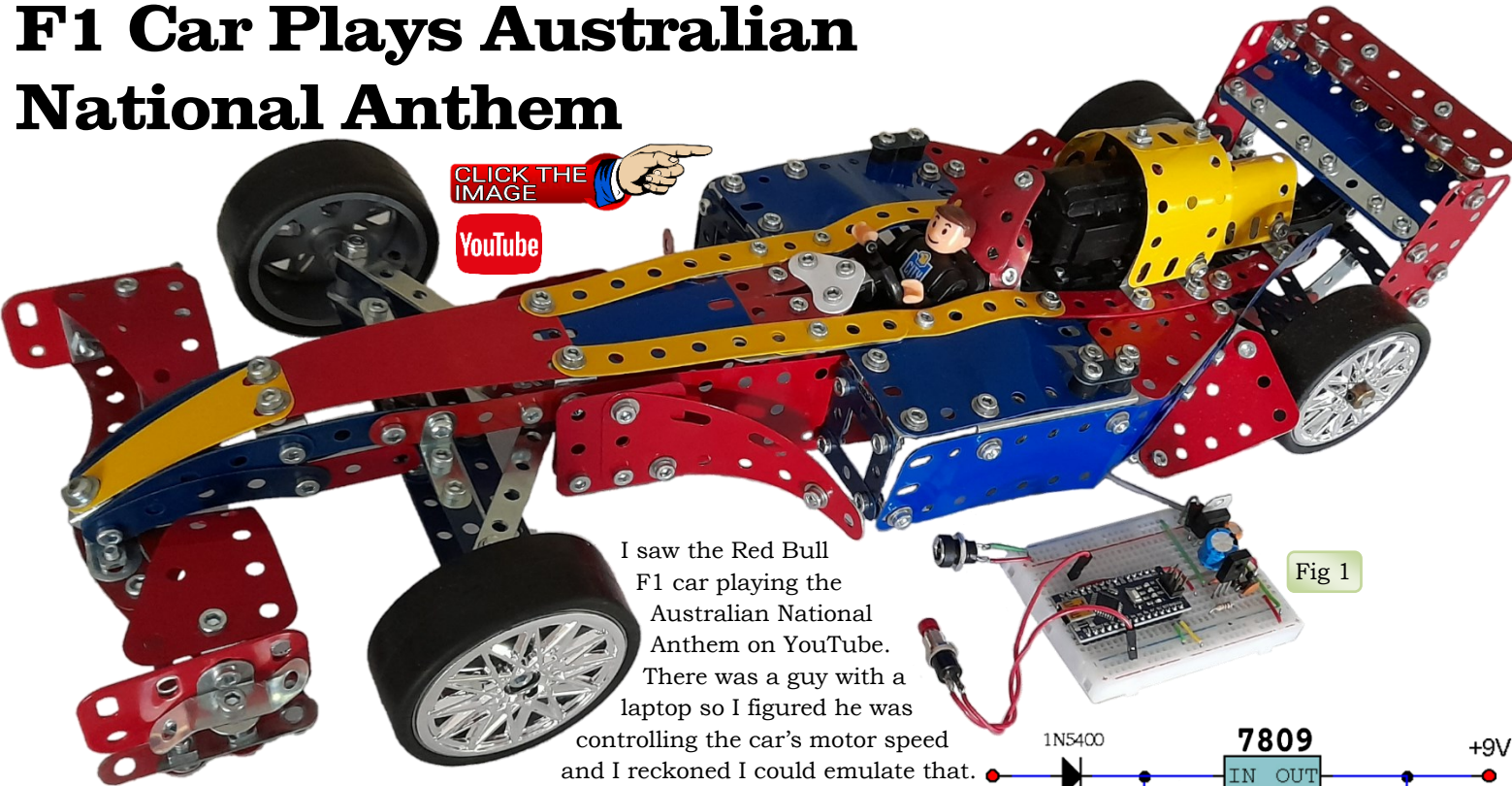

CLICK THE IMAGE
YouTube

I saw the Red Bull F1 car playing the Australian National Anthem on YouTube. There was a guy with a laptop so I figured he was controlling the car's motor speed and I reckoned I could emulate that.

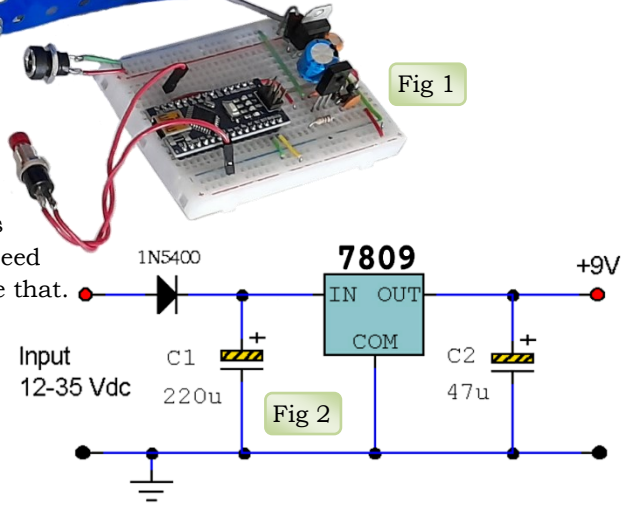

The first step was to rig up a motor to make a loud sound. I used a French Meccano motor but any can motor will do. To make the sound I used a plastic Pulley with 3 lengths of wire attached so they hit the plate. My first prototype used a Bushwheel with string, Fig 5, but it wasn't loud enough and the weight of the Bushwheel meant too much inertia, so it didn't change speed fast enough. The plastic pulley with wire, Fig 4, was lighter and louder. My test jig is shown in Fig. 6 and was first tested with a PWM before

I moved on to the Arduino control.

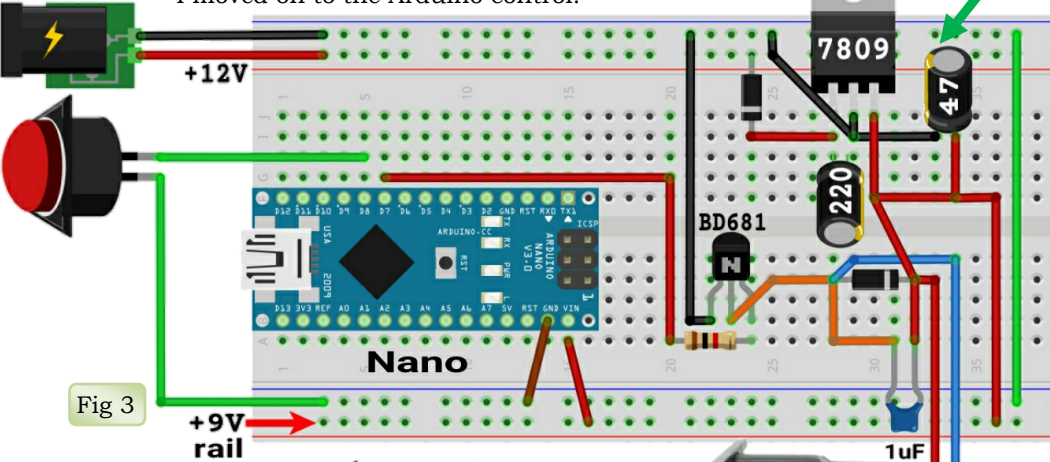

The Arduino is capable of PWM control but the PWM pins can't supply enough current for a motor drawing 1A so you need a transistor. I chose a BD681 Darlington pair simply because there was one in my parts drawer and it fitted the specs. The circuit diagram, Fig 7, shows how it's connected. The diode is to prevent back EMF and the 1uF capacitor is to suppress noise. My test jig worked from a 9V battery as long as the Nano was powered from the USB port but it failed when I ran the 9V to the Vin of the Nano.

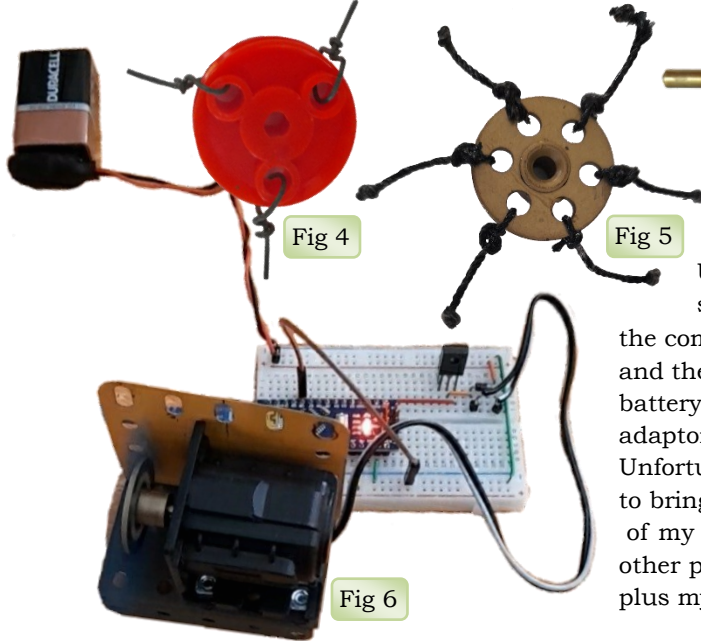

Using my benchtop power supply worked so I deduced that the combined current draw of the Nano and the motor was too much for a 9V battery. Rather than use a cumbersome benchtop PS, I had a few laptop AC adaptors laying around and they provide a regulated 12V 5A supply. Unfortunately, my motor was getting hot with 12V so I added a voltage regulator to bring it down to 9V. Fig 7. My Fritzing, Fig 3, is not an exact representation of my actual breadboard as I had difficulty adding parts without obscuring other parts but combine the Fritzing with the circuit diagrams in Figs 2 and 7 plus my actual breadboard photo in Fig 8 and you'll get the full picture.

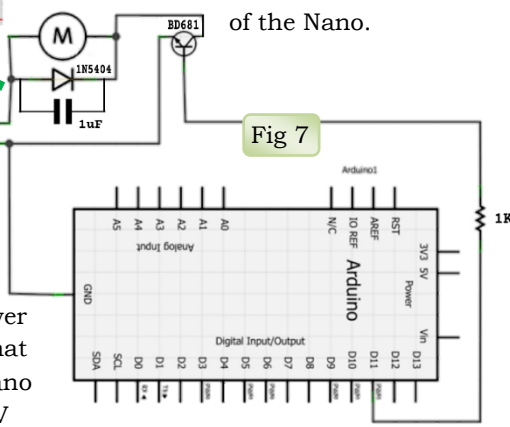

The Sketch

You can copy/paste the sketch from this article straight into your Arduino IDE as I have found a way to add code without losing the colour and formatting. Thanks to Dr Paul Dale for helping me with this code.

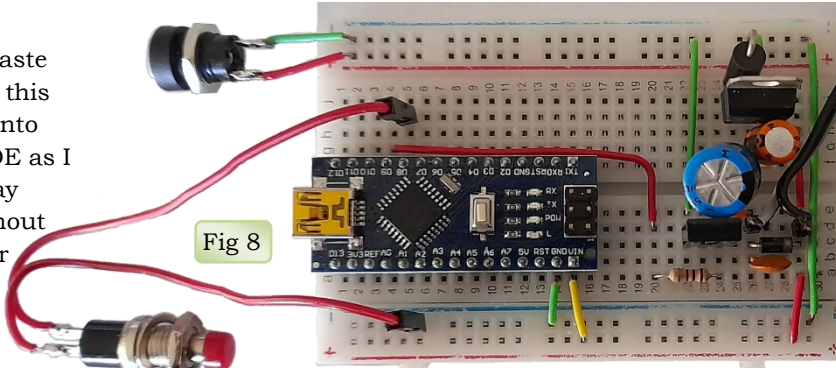

Fig 8



```
const int motorPin = 9;
const int startPin = 8;
```

```
#define note_C0 90
#define note_D1 100 // D
#define note_F1s 124 // F#
#define note_A1 146 // A
#define note_B1 170 // B
#define note_C1s 182 // c#
#define note_D2 200 // d
#define note_E2 215 // e
#define note_F2s 241 // f#
#define note_G2 255 // g
```

```
#define NOTE(freq, dur) { note_ ## freq, dur }
static const struct { unsigned char freq, dur; } notes[] = {
```

```
NOTE(A1, 2), // Write noteA Aust
NOTE(B1, 2), // Write noted stral
NOTE(A1, 2), // Write noteA yans
NOTE(D1, 2), // Write noteFsharp all
NOTE(A1, 2), // Write noteA let
NOTE(D2, 3), // Write noted us
NOTE(D2, 1), // Write noted re
NOTE(D2, 2), // Write noted joice
NOTE(G2, 2), // Write notefsharp For
NOTE(C1s, 2), // Write notee we
NOTE(A1, 2), // Write noted are
NOTE(F1s, 2), // Write notecsharp young
NOTE(B1, 2), // Write noted and
NOTE(G2, 4), // Write notee free
```

```
NOTE(A1, 2), // Write noteA with
NOTE(B1, 2), // Write noted gol
NOTE(A1, 2), // Write noteA den
NOTE(D1, 2), // Write notefsharp soil
NOTE(C0, 2), // Write noteA and
NOTE(A1, 3), // Write noted wealth
NOTE(A1, 1), // Write noted for
NOTE(A1, 2), // Write noted toil
NOTE(G2, 2), // Write notefsharp our
NOTE(C1s, 2), // Write notee home
NOTE(A1, 2), // Write noted is
NOTE(F1s, 2), // Write notecsharp girt
NOTE(D1, 2), // Write noted by
NOTE(C0, 4), // Write notee sea
```

```
};
```

```
static void play() {
  for (unsigned int i = 0; i < sizeof(notes)/sizeof(*notes);
i++) {
    analogWrite(motorPin, notes[i].freq);
    delay(300 * (unsigned short)notes[i].dur);
    analogWrite(motorPin, 0);
    delay(100);
  }
};
```

```
void setup() {
  pinMode(motorPin, OUTPUT);
  pinMode(startPin, INPUT);
  digitalWrite(startPin,HIGH);
}
```

```
void loop() {
  if(digitalRead(startPin) == LOW)
    play();
  digitalWrite(startPin,HIGH);
}
```

The code uses the digitalWrite command to send a PWM signal from pin 9. The values are 0-255 with 0 stopped and 255 full throttle.

My tests showed that the motor wouldn't run under 90 so the range had to be between 90-255. My mathematical formulas of mapping the pitch frequencies to values between 90 and 255 failed because the relationship was not linear. It really came down to using your ear so my daughter's keyboard was used to listen to each note and adjust the PWM digitalWrite value until it sounded right to my ear. You can see all the values for each note in the #define entries in the sketch to the left. It is easy to change and I'm sure you may need to change them to suit your setup.

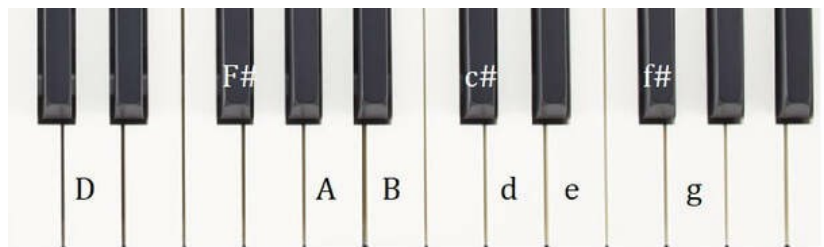

Fig 9

```
A d A F# A d d d f# e d c# d e
Australians all let us rejoice, For we are young and free;
A d A F# D A A B f# e d c# B A
We've golden soil and wealth for toil; Our home is girt by sea;
```

Fig 9, above, shows you the notes so use this to get your revs correct. Any change to the enclosure, motor, wire gauge or length, etc alters the notes so a final retune will be required.

You can simplify the electronics if you use a motor that's happy with 12V as you can dispense with the voltage regulator.

Fig 10, below, shows the 'echo chamber' that I used. Unfortunately, the wire will rip the paint to shreds so use sacrificial Meccano Plates or tin.



Fig 10

This article is about the Arduino control of a motor to play songs. You can change it to play any National Anthem or even Happy Birthday and you can use any car or even an empty can of Coke if you like!

If you want to build the Meccano Renault F1 model the manual can be downloaded for free from the NZMeccano site.

<https://www.nzmeccano.com/image-173222>



Red Bull F1 Car Revs Advance Australia Fair

14,384 views · 10 yr ago #F1 #Formula1 #Australia

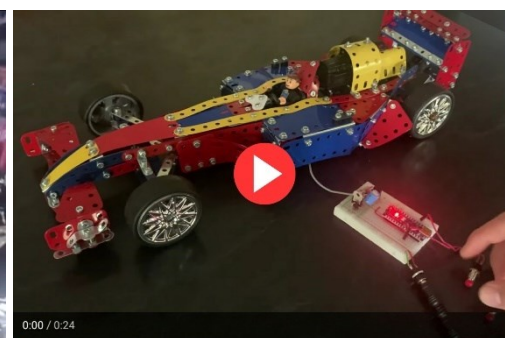

Meccano F1 car National Anthem

130 views · 1 day ago

Sydney Expo 2023



Joe Rimmer, L and Blue Neal



Chris Johnson and Winnie



Ashley Lamb



Michael Links

Steve B.

"The Meccano Set"



Murray Tulett

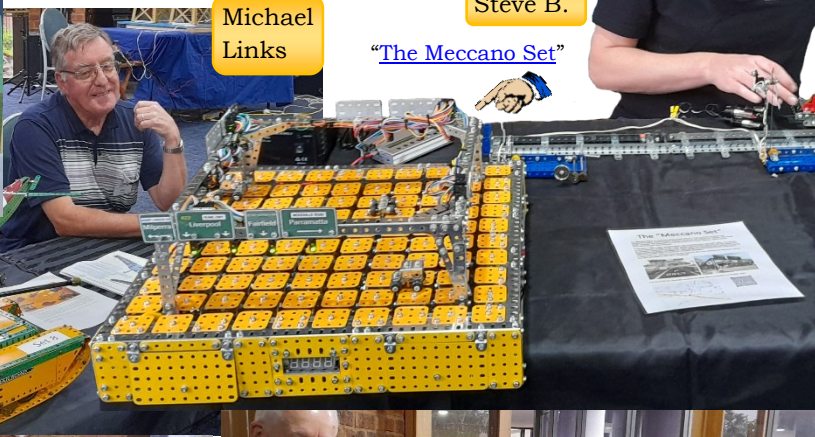

John Burke



Graham Jost



Lee Squires

I took my daughter Georgie to the Sydney Expo and while she went shopping, I enjoyed the best expo I've ever been to. Here are a few snaps and a full report will be published soon. – John.



Bugey, Ain, France by Peter Sullivan - Switzerland

Germain les Paroisses (Ain, France) 1 April 2023 St. Organised by Peter Sullivan in collaboration with the local village association "Autre-Choses Autrement" and some friends from the Rhône-Alpes Nord section of CAM, Jaques Baranger, Maurice Roussel, Georges Rollet and Francki Rasquier.



Francki and Maurice from CAM



Roger Tetaz, Francki & a visitor



Maurice & Jacques from CAM



Georges & Jacques from CAM



Welcome buffet snacks!



Local kids marvelling at Francki's tram



Maurice & Francki from CAM



Jacques (left) shows how big the fish was.



Peter Sullivan Stationary Engine



Tin Man Tom Santiago Plicio - UK

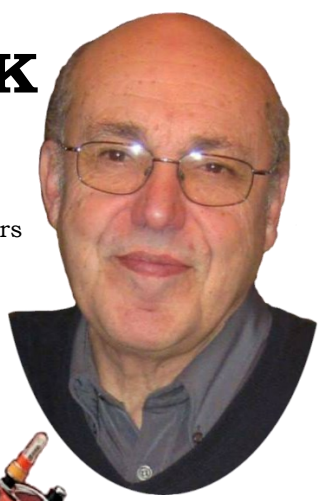

This has been a busy quarter of this year with new models and three club's Meccano meetings. Since WLMS I have built a marine engine from a model built by a well-known member and also, I just finished a new model of a cycling/peddalling Robot. With not good weather lately I only opted to be indoors and what better to keep busy than building Meccano! So, I thought what to build this time? A couple of ideas came to light and building a robot cycling on a vehicle was the one I took.

After my Space Invader robot, I needed to be sure that this new one should be quite different and with new ideas built to it. I first built the moving ribs mechanism and inserted into the new top square body, the head followed and then the two new arms and fittings. The idea of the legs cycling was part of this model, but I needed to fit the whole structure to a leg or supporting flat platform as it was very heavy, and pedalling would not be very practical. So, this supporting unit to hold the full weight should be very strong and will also help me in attaching the rotating drums for the pedals and its legs. I already built the main motor and driving system to move the head and arms and was tested working great. Now I needed another motor and gearing unit for the pedalling system. This was rather tricky and difficult, I only had about 6" space between the 4 supporting legs attached to the base, so getting a motor and reducing gears was rather problematic, but after many tries I came up with the final result and I was able to fit everything in the right position in that small space. A long axle from the motor will operate the two drums where the articulated legs will attach and work. Many adjustments and changes were made until all the movements were right. Finally, a new idea came about and that was the removal of the supporting base to be replaced with a bigger and stronger one, where I attached 6 wheels so the model can be pulled from one place to another. I thought to add a rotating unit built with circular plates and balls so the robot can manually turn in any direction from its standing position, so it can be displayed in many angles. It has been a difficult model, taking 12 days to build, but it did make me work quite harder than many of my other bigger models. Built in March. Santiago Plicio.

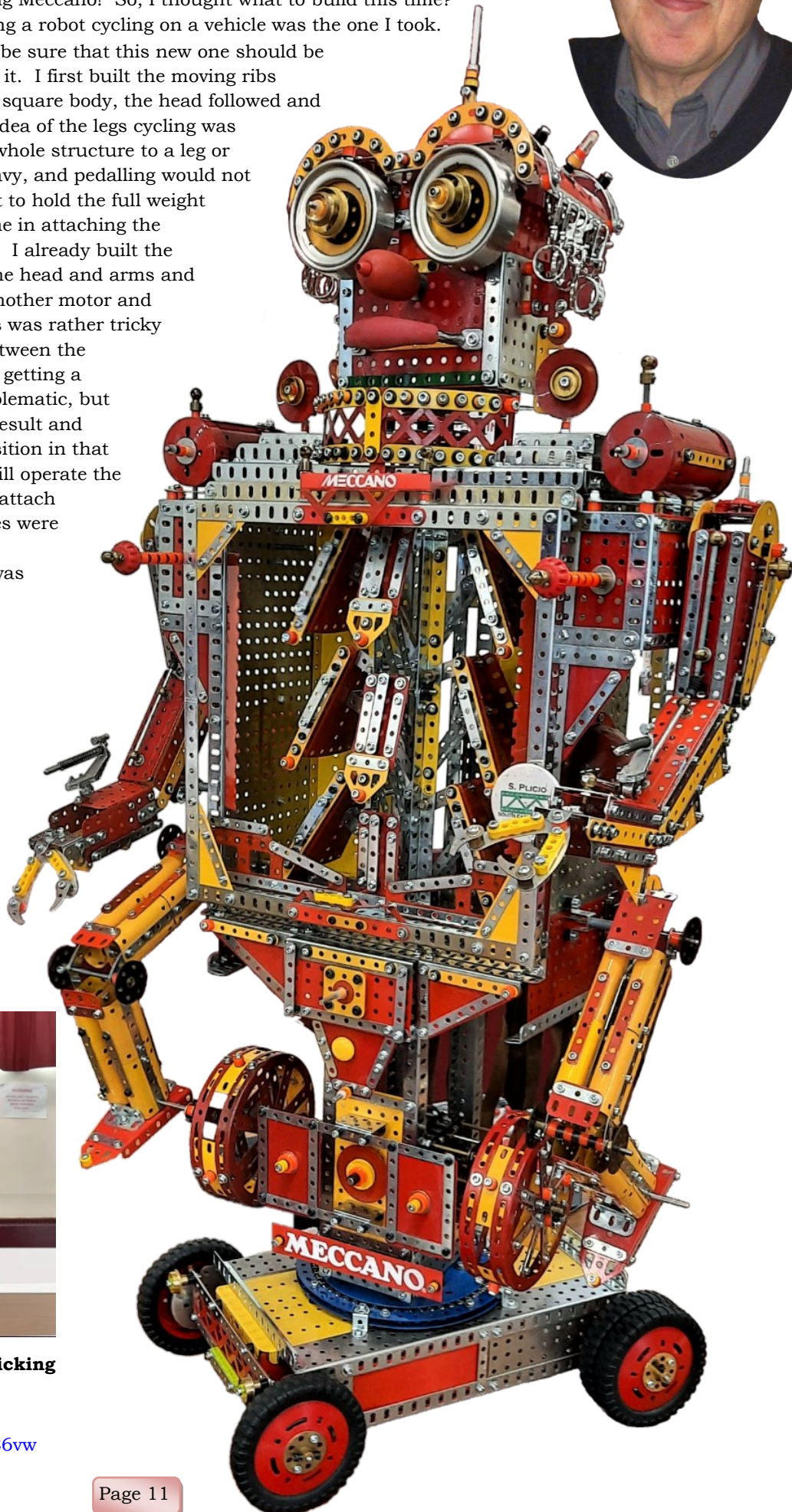

Watch Tin Man Tom on YouTube by clicking on the image above or the link below.

YouTube <https://youtu.be/Q71wbJYE6vw>

FROM OUR GOOD IDEAS DEPARTMENT

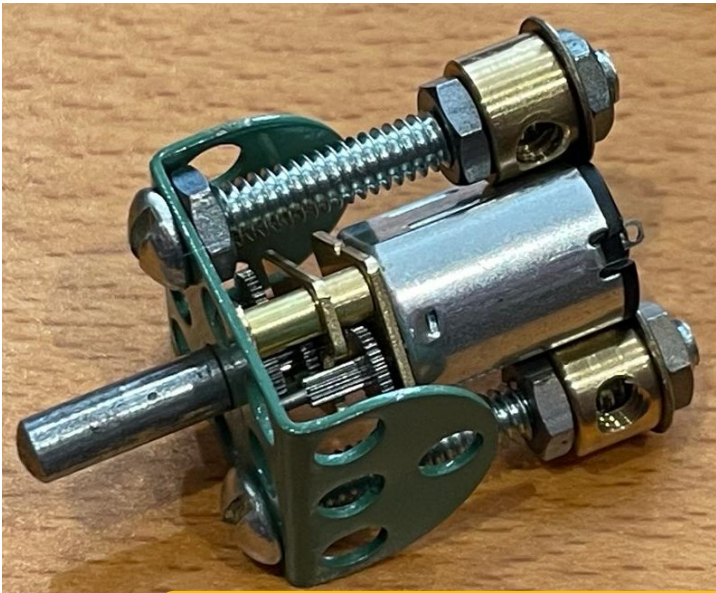

From Tim Gant. Mounting an N20 motor using only standard parts. No filing or drilling. Yet again we find that Frank Hornby had all the answers without going off into the wilderness.

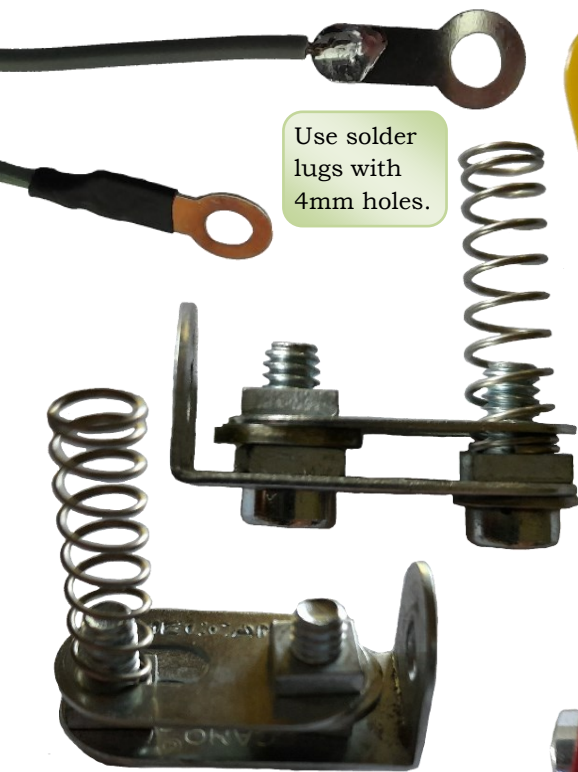

Use solder lugs with 4mm holes.

From John Burke. Indestructible Switch.

My experiences at Meccano expos have taught me that some kids like to break stuff. My F1 Car that plays the National Anthem by revving the motor at different speeds is started using a pushbutton switch. To allow the kids to start it, I designed this indestructible pushbutton switch. The Bolt on the lid contacts the Bolt inside the box that is mounted on a 5 hole plastic Spacer Strip (260c) for insulation. The Compression Spring holds the lid about 5mm above the 3x3x3 Cube. When the lid is pushed down, the Bolts make contact leaving about 1mm gap between the Cube and the lid. Any further extreme force will result in the lid touching the Cube and that's the limit. It can't be forced any further.

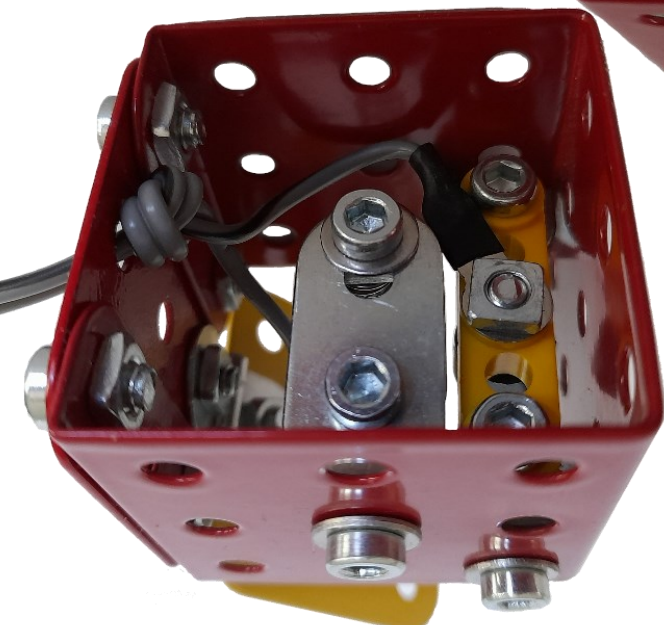

This Month's Meccanoboy

Charles Sherlock - Oz

When and where were you born?

Crown Street Hospital, in the heart of Sydney, 27 October 1945.

What did your parents do for a living?

After WW2 service in PNG as a (young!) chaplain, Dad was a parish priest around Sydney. He was a 'rector', so mum called herself the di-rector! Despite limited means, they were generous, dedicated and kept in touch, though we saw quite a few things differently.

What schools did you go to?

Primary – Milton, Campbelltown and Granville Public Schools (NSW). Won a scholarship to The Kings School Parramatta for secondary – the contrast of being a day boy from industrial Granville at Australia's oldest school made me a 'comrade'. NB: I used to wait for the train under the bridge where the terrible Granville accident happened in 1977.



At Kyneton with my version of the NebulaZ.

When did you get your 1st Meccano set?

A well-off spinster in Milton gave me a Meccano 2 Set for my fifth birthday. My Meccano Guild certificate, signed by Roland Hornby, is dated 3 January 1952. Accessory sets, and then parts from a list I gave Mum and Dad (she'd choose the 'pretty ones' in HobbyCo), were my birthday and Christmas presents until I was 21 and left home. After 15 birthdays and Christmases I was enjoying a Set Ten.

What subjects did you study at university?

I did a BA at Sydney Uni on a Commonwealth Scholarship 1963-66, doing Honours in Pure Maths and Maths Stats, plus Latin, Applied Maths and some Physics. I was active in the folk club (I play 5-string banjo) and Christian Union. I was in the first Vietnam ballot: my date didn't come out, but this opened my eyes to SE Asia.



Charles with the curls, left, my mother Emily and my sister Elizabeth.

How did you meet your wife Peta?

My Honours year was funded by the Aust Bureau of Stats, so it was off to Canberra in 1967 to be a Research Officer. Peta was in her final year at Australian National University, and we soon 'clicked'. We had folk music and faith in common. She headed to Sydney for DipEd in 1967, then home to teach in 1968, while I moved to Melbourne to study Theology. So, we courted by mail until we wed on the middle Saturday of February 1970 – Valentine's Day, though we did not realise it then!

How many children do you have?

We lived in a flat at Ridley College, where Jonathan arrived in December 1970, then Peter in October 1972.



Isn't it confusing having Peta and Peter?

Not really – he's a bloke, she's a sheila. And he was always 'young Peter' at home. Now Professor Peter!

Peter, left, and, Jonathan, right, with my blocksetting crane at Ridley, 1976.

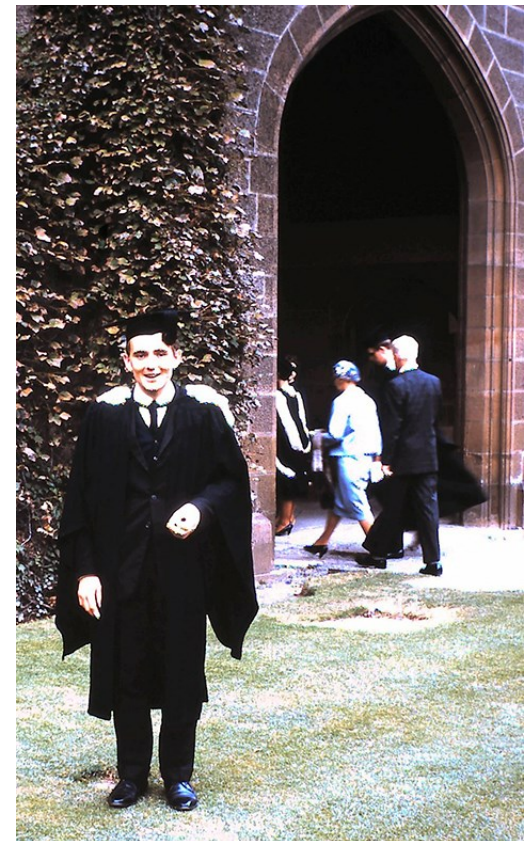

Graduation from Sydney University, 1966.

Why did you move from statistics to theology?

The Vietnam War made me aware of SE Asia, and the need for theological education there. The Overseas Missionary Fellowship (the former China Inland Mission) encouraged me to study theology – but finding a college open to other than training clergy was a challenge. Ridley in Melbourne was a uni college, so I headed there, both as a stats tutor and theology student. And if stats is about how ideals and reality blend ... so is theology, but from a much wider viewpoint!

On finishing my BD, I was surprised to be asked to join the staff. After three 'apprentice' years we headed for Taiwan with OMF for Chinese study (which I loved), but illness cut this short. I ended up back at Ridley in 1975, teaching there for two decades. I was ordained in 1977, and we moved to Brunswick (it was cheap then!). Jono and family live there still.

Charles Jnr and Charles Snr. Speech Day 1962 at Kings School, when I was Dux of the school.

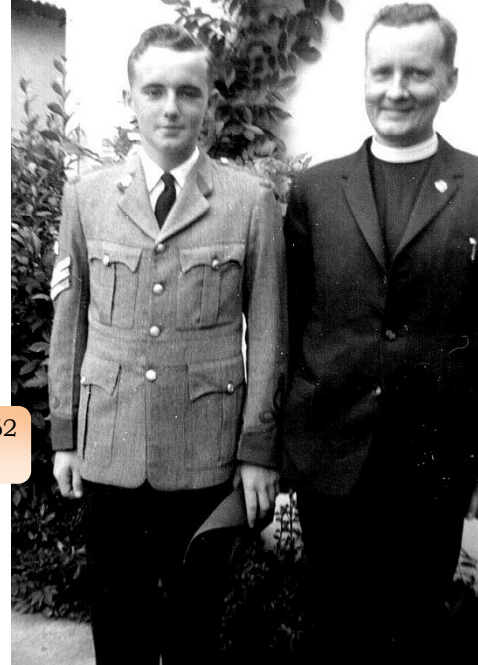

Do you speak any other languages?

Used to speak Chinese (Mandarin) – with a Beijing accent! – but it has largely gone. I can do basic shopping in French, which I can read, plus Latin, Hebrew, Greek and some German (though dictionaries are being opened more now).

Did your studies involve travel?

We spent time in Singapore in culture training before Taiwan, which involved language studies. Academically, I had two study leave years from Ridley: in 1982 at Yale, New Haven Connecticut (where I was a Den Mother for Cub Scouts) and in 1989 in Nottingham. Both were hugely important for my ongoing learning, and experiencing the calendar, weather, school, sports, church etc. years in different settings.



Wedding bells. Valentines Day 1970

L-R. Doctoral graduation. Charles, Peta, Jonathon, Mum, Peter and Dad



Tell me about that ten set you sold when money was short.

The boys went to Brunswick North Primary and Brunswick High, where I was involved in school councils, and faith was fun in our struggling local church. But they had little interest in Meccano, money was tight, and when I was offered a deal by a farmer, I could not refuse it ... By then it was a full 1950s Ten Set plus 30-40% in common parts, both Gears sets, an E20R and a clockwork motor.

The 4 doctors. L-R Craig (Peter's husband), Peta, Charles and Peter at Peta's doctoral graduation.



L-R Peter, Peta, Jonathon, Charles at home in Brunswick.

Where are you living now? In 1992 Peta was one of the first Australian women ordained priest. She had a decade at North Fitzroy and four years at Heidelberg before moving to Bendigo as Dean of the Anglican Cathedral. From 1998 we shared a ('holiday') house in 'cool country' Trentham (it was cheap – not now!) and enjoy its people, history, gardens and spuds (potatoes). We'd moved to our own place before Peta retired in 2011 and downsized in 2021 on the front of the block. We love Trentham!



What other hobbies and interests do you have?

I've played 5-string banjo (and guitar) since I was twelve – bluegrass, country and folk – and sing at local markets. Peta and I play Scrabble daily, read a fair bit and enjoy TV dramas. When the nest emptied, we tried cruising, and loved it – we're Elites on Princess. Our Golden Wedding six-week wander around the Indian Ocean saw us scrape home two days before Covid closed borders.

I'm grateful to have got past 75 in reasonable health. The last decade has given me space (sometimes onboard ship) to finish several books: writing is a significant part of my life. In retirement I enjoy gardening, helping out at the Reserve across the road, and committee work for our Men's Shed, Community Bank (Bendigo) and Health Service. St George's is where my heart lies beyond home, I'm the fill-in minister for 2023.

When did you get back into Meccano?

At an auction, I opened a large box to find Meccano in Tupperware containers – and I was back home! Soon found Melbourne Meccano Club Inc, and I now have around three Ten Sets plus bits and pieces. I have become a regular at the Kyneton Labour Day weekend and try to get down to MCCI meetings. I've learnt a lot though the Club and my modelling has improved. I enjoy the Ten Set Model Plans from the UK. I recently built my first self-designed model, the Blackpool Tower – and a dragon for St George's Day.

Any regrets?

Having to sell my boyhood Meccano set.

Will Trentham be your final resting place?

Yes – this side of heaven! It's home until we slip into grave C69 in Trentham Cemetery.

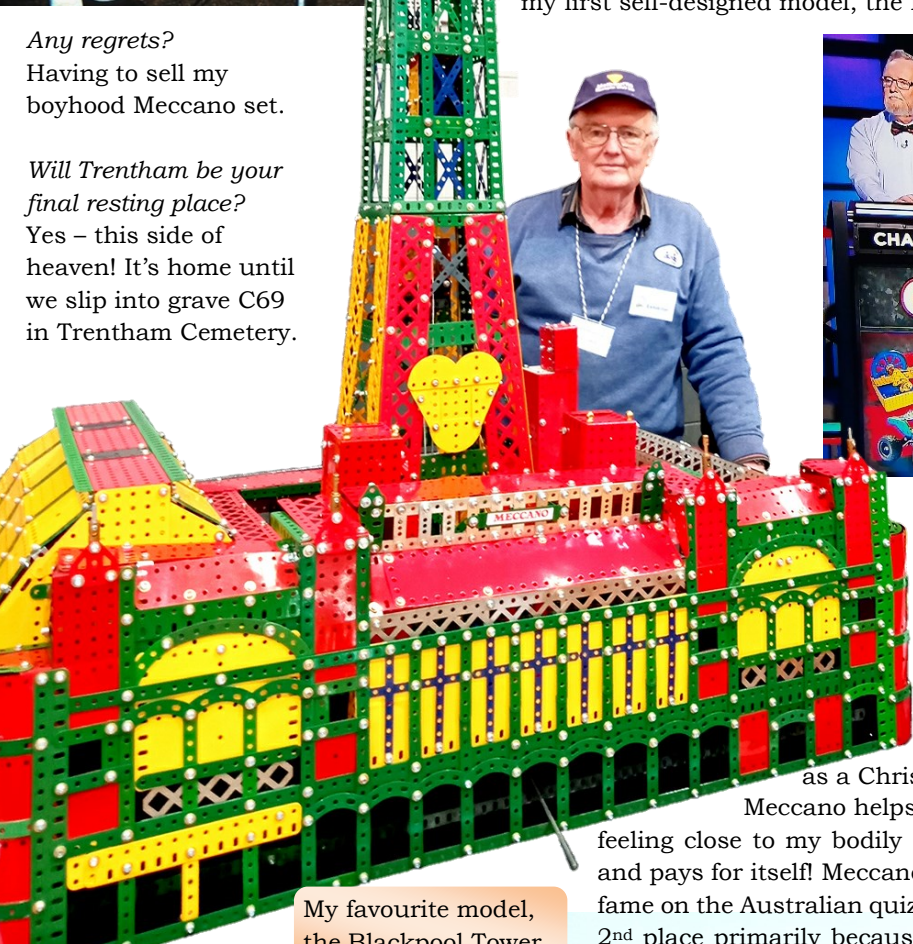

My favourite model, the Blackpool Tower.



My St George's Day dragon.



How has Meccano helped you in life?

I've been a 'head' type from an early age, and as a Christian am 'heart' oriented.

Meccano helps keep my thinking and feeling close to my bodily self, stimulates my creative side – and pays for itself! Meccano helped me gain my 15 minutes of fame on the Australian quiz show Hard Quiz. I was beaten into 2nd place primarily because I misheard a key question – but really, I did know that question about Ackermann steering!

Do you have any theological advice for the sadness I'm feeling when fellow Meccano friends are dying of old age and seeing the numbers of Meccano people drop so rapidly?

Give thanks for what these friends meant to you and commend them to God's care. Pray for those facing death, accept that interests keep changing, and enjoy the gift of life with eyes on the future.

What's your advice for young people today?

Engage with others face to face – online is about perceptions more than reality! Pray – a practice that opens us beyond self – and never stop being curious.

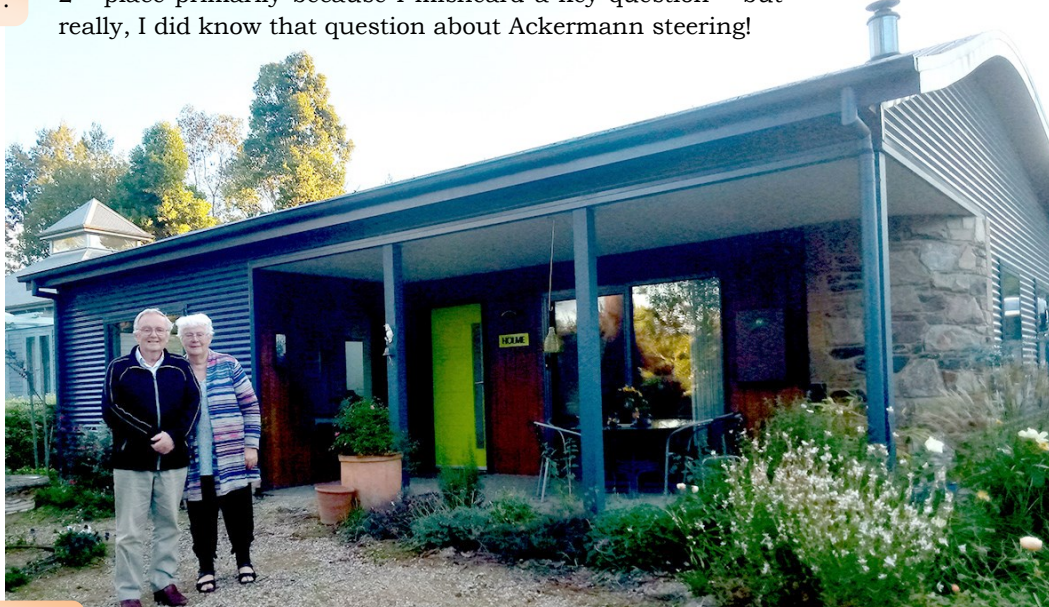

Charles and Peta at home in Trentham.

We are John & Johnny. A father and son team who like Meccano. We're nothing to do with Spin Master who own the brand. Contact us at



MeccanoNews@gmail.com

Follow Johnny Meccano on



facebook



text

text

text



UK

- <https://tims.org.uk>
- <https://nelmc.org.uk>
- <https://nmmg.org.uk>
- <https://www.selmec.org.uk>
- <https://southwestmeccano.org.uk>
- <https://londonmeccanoclub.org.uk>
- <http://www.hsomerville.com/wlms>
- <http://www.northwestmeccano.co.uk>
- <https://northeasternmeccano.org.uk>
- <https://www.meccanoscotland.org.uk>
- <http://www.corlustmeccanoclub.co.uk>
- <https://runnymedemeccanoguild.org.uk>
- <http://www.midlandsmeccanoguild.com>

Other Countries

- <http://club-amis-meccano.org/>
- <http://www.meccaninfos.com.ar/>
- <http://www.meccanogilde.nl>
- <http://meccano.free-bb.fr/>
- <https://www.aceam.org/es/>
- <http://www.amsclub.ch/>
- <http://www.meccanoweb.es/>
- <https://www.metallbaukasten-forum.de/>
- <http://www.la-roue-tourne.fr/index.php/le-meccano/notices-et-plans>

USA and Canada

- https://www.spinmaster.com/brand.php?brand=cat_meccano
- <https://www.usmeccano.com>
- <http://www.meccano.com>
- <http://www.cmamas.ca>
- <http://www.bcmeccanomodellers.com/meccano-in-canada.html>
- <http://www.meccanoquebec.org/index2ang.html>
- <http://www.melright.com/meccanosales/>

New Zealand

- <http://www.nzmeccano.com>
- <http://www.nzfm.co.nz>
- <https://www.facebook.com/MWT-Meccano-Club-1476153515979522/>

Australia

- <http://www.mmci.com.au>
- <http://www.sydneymeccanomodellers.org.au>
- <http://www.webjournalist.com.au/maylands/index.html>

South Africa

- <https://www.facebook.com/Meccano-Club-of-South-Africa-464753870326296>
- <http://www.mecworld.co.za/cmpr/>

Personal pages

- <https://neilsmeccanoandstuff.jimdofree.com/neil-s-meccano-models>
- <http://www.users.zetnet.co.uk/dms/meccano>
- <http://www.dalefield.com/meccano/index.html>

- <https://www.alansmeccano.org>
- <https://www.meccanoindex.co.uk>
- <http://www.meccanokinematics.nz>
- <https://meccanocreations.in>
- <http://www.meccano.us>
- <https://mecca-clocks.fr/>

Meccano suppliers

- <http://www.meccanohobby.co.uk>
- <https://www.meccanoshop.co.uk>
- <http://meccanoman.co.uk/catalog>
- <https://www.meccanospares.com>
- <https://ralphsshop.com>
- <http://www.meerlu.com.au/>
- <https://tinyurl.com/AshokBanerjee>
- <http://www.hsomerville.com/mwmailorder>
- <http://www.metalconstructiontoys.com>

Mecgear Jeff Clark New Zealand
sales@mecgear.co.nz No website yet but a
 pricelist with photos can be downloaded here
<http://www.nzmeccano.com/image-151916>
 Bespoke parts from Corlust Meccano Club
 Ian Wilson bespokecraftshack@gmail.com
 Mike Rhoades. Link to price list below.
<https://www.nzmeccano.com/image-165106>

Well? Was it worth the price of a cup of coffee?



Buy me a coffee

A man enters a barbershop for a shave. While the barber is foaming him up, he mentions the problems he has getting a close shave around the cheeks. "I have just the thing," says the barber taking a small wooden ball from a nearby drawer. "Just place this between your cheek and gum."

The client places the ball in his mouth and the barber proceeds with the closest shave the man has ever experienced.

After a few strokes, the client asks in garbled speech: "And what if I swallow it?"

"No problem," says the barber. "Just bring it back tomorrow like everyone else does."

Why do elephants have big ears?
 Because Noddy wouldn't pay the ransom.



A woman went to the market to buy some cod. She approaches the fishmonger for assistance.

- Woman: Do you have any cod? I'd like a piece of cod.
- Fishmonger: We've got no cod, madam. We have haddock, would you like some haddock?
- Woman: No, I'd like some cod.
- Fishmonger: We don't have any cod. Can I offer you some salmon?
- Woman: No, I would like cod.
- Fishmonger: We have no cod, madam.
- Woman: Give me a piece of cod please.
- Fishmonger: Madam, I'm not sure how I can make this any plainer to you, but we have no cod.
- Woman: But I want a piece of cod
- Fishmonger: Well, I'm sorry but we have no cod
- Woman: But I insist I want a piece of cod
- Fishmonger: Madam, let me spell it out for you "N-O, C-O-F-D!"
- Woman: But there's no F in cod
- Fishmonger: That's what I've been trying to tell you!

